

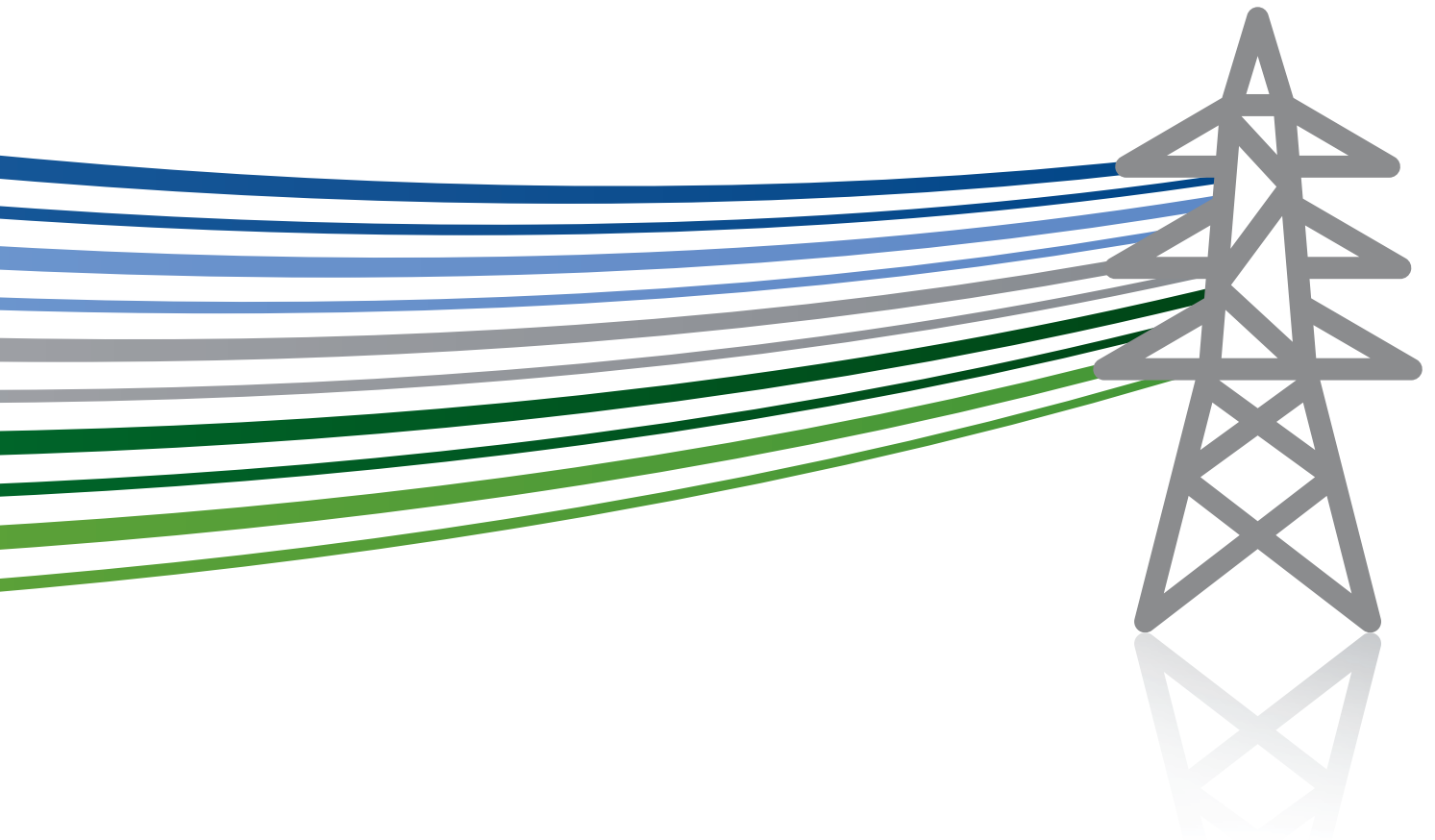

NINES

7A Knowledge and Learning Report



Prepared by

Document Owner(s)	Project Role
George Bell	Project Lead, University of Strathclyde
Han Xu	Researcher, University of Strathclyde
Fulin Fan	Researcher, University of Strathclyde
Ivana Kockar	Principal Investigator (academic lead)
Stevie Adams	SSEN Senior Project Manager

Executive summary

Executive summary

This NINES Knowledge and Learning report presents the findings from the University of Strathclyde research and analysis project which followed the initial NINES investigation during the period 2011-2013.

This subsequent phase was requested by Ofgem to analyse and present the learning from implementation of the earlier identified opportunities for introducing efficiencies in the operation of the Shetland electricity network, by a combination of renewable generation, a Battery Energy Storage System (BESS) and Domestic Demand Side Management (DDSM), with related services.

University of Strathclyde has a solid history of collaboration with SSEN on energy and grid-related research over a number of years, with contributions from a number of academic faculties and departments. The main research team members in the current project phase were drawn from the Electronic & Electrical Engineering (EEE), Energy Systems Research Unit (ESRU), and the Fraser of Allander Institute (FAI) departments, to provide a multi-perspective engineering and economics view of the challenges and proposed solutions. The commercial firm Smarter Grid Solutions (SGS), responsible for the Active Network Management (ANM) product, was also involved in aspects of this project, and regular discussions were held with other major subcontractors, including Glen Dimplex, Airwave, and customer groups such as Hjaltland Housing Association (HHA).

This research project phase with University of Strathclyde ran for a period of 18 months, and analysed in some detail the generator connections, the operation and control of Domestic Demand-Side Management charging profiles (using storage heaters and hot water tanks) in conjunction with intermittent renewable energy connections (mainly from wind generation), and the effect of a 1MW/3MWh storage battery on the network. The results should aid the decisions of the DNOs and National Grid in optimising energy management scheduling and frequency response of the network. It should also contribute to reducing operating expenditure and may aid the setting of optimal energy tariffs for the Shetland consumers.

The Project integrated a grid-scale BESS and DDSM with an ANM system. Major findings, which are discussed in detail later, are:

- NINES has proven that a distribution system can be operated securely with a high penetration of renewable generation supported by ancillary services from thermal plant. It has also been shown that renewable generators connected via managed connections can experience increased levels of constraint in periods of low demand.
- Frequency responsive DDSM has been shown to contribute to stable network operation in conjunction with an ANM system. It has also been shown that frequency responsive demand can be used to maintain the frequency stability of the system under the calculated limits.

Contents

Table of Contents	
Executive Summary	2
Table of Contents	3
List of Figures and Tables	4
SECTION 1 – Context and Background	5
Project Background	5
NINES Elements	5
NINES Aims and Objectives	7
Agreed Learning Outcomes	9
Project Structure	16
Relevance of NINES to other initiatives	16
SECTION 2 – Modelling & Analysis contributing to Learning Outcomes	19
Infrastructure and Technology	19
What was learned?	26
Operational and Network Benefits	28
SECTION 3 – Additional Learning Identified	37
ANM	37
DDSM	37
Renewable Generators	39
Battery	39
Operational impact	40
SECTION 4 – Dissemination activities	42
SECTION 5 – Conclusions and main recommendations	48
APPENDICES	51
1. Modelling Approach	51
2. Source Documents for the LO Questions	53
3. List of Contributors	54
4. Glossary	55

List of Figures

Figure 1	NINES in context of other projects	18
Figure 2	overview of NINES elements	20
Figure 3	Schematic representation of the 33kV Shetland network	20
Figure 4	NINES ANM connections	21
Figure 5	DDSM Infrastructure	23
Figure 6	Battery Installation	23
Figure 7	Power outputs (MW) of the 1MW, 3MWh BESS (charge rates are negative and discharge rates are positive) and corresponding variations in SOC (%) within a full cycle from 07:00 on 03/09/2014 to 07:00 on 04/09/2014	24
Figure 8	Total demand (MW) to be met by generators varying with the BESS's operation from 07:00 on 03/09/2014 to 07:00 on 04/09/2014	30
Figure 9	Average import (kW) of each flexible DDSM group per day over the year 2016/17	31
Figure 10	flexible demand and margin of stability	34
Figure 11	Maximum wind generation (SVT offline)	35

1. Project Background

In 2010, a licence obligation was put in place requiring Scottish and Southern Electricity Networks (SSEN) to present an Integrated Plan to manage supply and demand on Shetland. The Shetland Islands are not connected to the main GB electricity network and, as such, face unique electrical challenges – but also a unique opportunity to decarbonise supply.

Under the licence condition, this Integrated Plan was required to demonstrate that it had identified a solution based on the lowest lifecycle costs, taking into account its environmental obligations.

As part of the Integrated Plan submission, consideration was to explore, amongst other things, the upgrading or replacement of Lerwick Power Station, the impact of third party generation requirements, the abundance of renewable energy resources and the future demand on Shetland. The factors influencing the supply and demand issues on Shetland necessitated an innovative approach to their management. However, with innovation comes the need to trial solutions before reaching an answer. As a result, SSEN originally proposed to split the implementation of the Integrated Plan into two phases:

Phase 1 Shetland Trial (Northern Isles New Energy Solutions 'NINES') – implementation of the infrastructure necessary to actively manage demand, generation, reactive compensation and energy storage assets. These elements were coordinated to maximise the amount of energy harvested from renewable generation while maintaining supply quality and security. In doing so, two principal effects are achieved:

- a reduction in maximum demand; and
- a reduction in the electricity units generated by fossil fuels

Phase 2 (Shetland Repowering) – upgrading or replacement of Lerwick Power Station by SSEN, taking into account the learning acquired during Phase 1 and, where appropriate, extending the Phase 1 technology.

NINES Elements

NINES was originally designed and developed to operate in conjunction, and integrated, with Lerwick Power Station or its replacement operated by SSEN, and was developed with the main aim of informing the optimum repowering solution. Whilst its primary objective was to trial 'smarter' initiatives, importantly NINES has funded elements and infrastructure that are expected to endure as part of, or alongside, the new energy solution. Central to the project has been the creation of an integrated set of models designed to anticipate the impact of NINES, covering the following themes:

- Dynamic Stability
- Steady State
- Unit Scheduling
- Customer demand forecast
- System Development optimisation
- Strategic Risk and Operational risk
- Shetland Economy
- Commercial

Facilitated by modelling and practical learning, the aims of NINES have been to:

1. Increase understanding of how best to accommodate Shetland's significant wind potential on a small distribution network; and
2. Increase understanding of how the existing and known future demand on the island can be best managed on a constrained, isolated system.

These models served to predict the behaviour of the energy systems on Shetland, and to validate each of the key elements of NINES as they were added. Following this validation process, these models have been used to inform the development of the New Energy Solution realised through the competitive process. With the successful operation of NINES, the infrastructure and knowledge to reduce the peak capacity requirement for any replacement solution to a level dependent on the particular assets connected, and the characteristics of the new solution has been determined. The NINES project assets are described below.

1MW battery at Lerwick Power Station

A 1MW battery acts as an energy storage system on the Shetland Network. In addition to facilitating the connection of new renewables, the battery assists in optimising and stabilising the operation of the existing island network by helping to reduce demand peaks. The battery has helped to accommodate the connection of a significant amount of new renewable generation that would otherwise not have been able to connect.

Domestic demand side response with frequency response

SSEN has worked with Hjaltland Housing Association to install advanced storage heating and water heating in 223 existing homes, which was the total number of homes participating in NINES DDSM as of March 2017. These new storage and water heaters (which replaced existing traditional storage heaters) were provided through Hjaltland and ERDF funding and have been specifically designed to use a much more flexible electrical charging arrangement. This new charging arrangement is determined based upon the predicted demand, weather forecasts, availability of renewables and any other network constraints. This initial roll out was intended to help gauge the effectiveness of storage and demand side response at the domestic level.

The heaters incorporate additional insulation to minimise heat loss and are fitted with programmable timers to allow users much better control of temperature and operating times when compared with conventional storage and water heating systems. The new heating system is designed to be more efficient, while giving the customer full control of both temperature and operating time and allowing for charging at times that best suit the network.

Renewable generation

Shetland has some of the richest renewable resources in Europe and there is significant interest on the islands to connect a range of new renewable generators. There is a mix of wind and tidal generators currently connected that range in scale from 45kW up to 4.5MW. However, before the advent of NINES these generators could not connect to the network due to the underlying voltage and stability constraints. Connecting more renewable generation, which is unavoidably intermittent, would have exacerbated these problems.

To address this, NINES has trialled an ANM regime which has offered renewable connections to developers. In return, they are required to give their agreement to being constrained when the system cannot accommodate their generation. The measures that have been developed and trialled under NINES are reducing this constraint by being able to actively provide demand when there is renewable resource available.

Indeed, these arrangements could be necessary even if Shetland is to become electrically connected to the mainland at some point in the future. If a single mainland link is damaged, this could result in a prolonged outage, which would mean that Shetland would once again be electrically islanded. Therefore the prospect of and ability to constrain will remain for generators on Shetland, albeit on a less frequent basis.

ANM System

This is the NINES project's nerve centre: it monitors the different parameters affecting the network, including embedded constraints, frequency stability and weather and manages an appropriate response. It responds to, and tunes, the models which are being developed to monitor and understand how new storage assets will behave. By creating flexible demand on the island progress has been made in exploiting and maximising Shetland's wind generation potential on an islanded basis, and in reducing the generated output from replacement thermal generation.

A key driver for the trial has been to develop an understanding how these technologies work and interact in a real-life environment. The learning from NINES has demonstrated that in general terms (with the exception of additional renewables), all NINES technologies predominately involve energy shifting rather than energy reduction.

The following report is one of a number of related reports undertaken by the research team, led by University of Strathclyde and focuses on the main project findings, without excessive detail which might obscure the main message. The detailed reports and conclusions generated by each of the research streams are available on the NINES website for referral by those who have a specific interest in a particular area. These reports are referenced throughout this document, however only the more significant outcomes and observations from each have been incorporated in the following narrative. (See Appendix (2) for full list of reports and links).

NINES Aims and Objectives

The main focus of the project was to increase understanding of:

- how best to accommodate Shetland's significant and variable wind generation resource within the distribution network; and
- how the existing and future energy demand can best be managed within a constrained, isolated system.

DDSM

The DDSM element of NINES uses innovative "smart heaters" remotely controlled by an ANM System to store energy in heating and hot water appliances located in homes during periods of excess electricity supply. Prototypes of these 'Quantum' storage heaters and hot water tanks, developed by Glen Dimplex, were trialled in 6 houses in Lerwick from 2011-2013. Glen Dimplex incorporated lessons learned from that trial into the design of the production versions, which were installed between July 2013 and October 2014 in 234 electrically heated properties owned by the Hjaltland Housing Association (HHA). The details on the impact of DSM, infrastructure requires and network benefits in NINES are presented in in *1A Customer Impact*, *1B DDSM Infrastructure*, and *1C Network Benefits Report*, respectively.

Battery

A BESS rated at 1MW, 3MWh and using lead-acid technology was installed on the network to assist with load-levelling and to support both the variable wind generation inputs to the network and variable demand profiles of the consumers. Initially, a 1MW 6MWh NAS battery was planned to be installed at LPS. However, after an incident involving the same technology in Japan, and after consideration of the risk assessment, SSEN concluded that due to safety concerns related to the location of this installation at LPS, NAS was no longer a suitable technology to be used on Shetland. Details on the NINES BESS operation and its operational effectiveness are given in *2A Battery Operational Effectiveness Report*.

Frequency Response

An important area of research was to determine how frequency-responsive elements of the network could be managed to reduce frequency excursions to a minimum. On the mainland of Great Britain, the frequency response is managed by National Grid, however due to the islanded network in Shetland, SSEN are required to manage and control frequency response in that area. Due to the relative size of the Shetland network, i.e. very small in comparison to mainland Britain, there is potential for a wider excursion in the actual frequency of supply. The grid code limits are currently 50Hz (+/-1%), however as an islanded network is subject to potential wider excursion, the research considered +/-2% limits. Assessment of the impact of frequency-responsive DDSM on the Shetland's network frequency stability is carried out in two aspects, which are commercial impact detailed in *3A Commercial Impact Report* and operational effectiveness detailed in *3B Operational Effectiveness Report*.

Renewable Generation

Shetland has a rich source of renewable generation potential, from wind, wave and tidal energy. Previous to NINES, and again due to the islanded network, there was limited scope for connecting intermittent generation. At that time, there was less than 4MW of renewable generation connected, with no further connections possible in order to preserve the stability of the network. Therefore, one of the main aims of the NINES programme was to increase the amount of renewable generation allowable on the network.

Agreed Learning Outcomes

A list of eight questions has guided the process of research and analysis throughout the NINES programme, and these are presented here for reference, along with representative responses, which are expanded elsewhere in this report and the detailed work package reports.

LO 1. How can a distribution system be securely operated with a high penetration of renewable generation?

Through application of ANM, flexible connections, the 1MW battery and DDSM, NINES has proven that a distribution system can be operated securely with a high penetration of renewable generation. NINES has proven that by controlling these solutions centrally, increased levels of renewables can be connected while maintaining system reliability and safety.

- DDSM was expected to contribute to replacing fossil fuel generation only when at least 14MW wind is connected, and the current wind capacity is well below this. With 19 MW of wind installed, the current deployment could displace 385 MWh of fossil fuel each year;
- *NINES 6A Commercial Arrangements and Economics Report* determined that DDSM flexible appliances alleviated the curtailment of 77MWh of renewable energy (generated by North Hoo and Luggie's Knowe), during the period of February 2016 till January 2017. Also, the *NINES Report 1C DDSM Network Benefits*⁴ has concluded that, moving houses from teleswitching to DDSM reduced their maximum possible load at peak times by 0.5 MW as long as the devices followed the imposed schedule. This results from altering fixed schedule times as much as from flexible scheduling. However, unlike teleswitching, DDSM heaters can be charged beyond their schedule. The benefits from frequency response of DDSM were restricted as frequency excursions were in the under-frequency events. In those instances, the DDSM devices could have provided support only if they were in the charging mode, and then were switched off to contribute to network stability. However, charging takes place over around 8 hours at most each day and so far the Lerwick Power Station has not relied on this functionality operationally;
- On average, only around 50-60% of installed capacity was reliably visible and available to the network on any given day. The precise reasons for a significant proportion of appliances being unavailable vary and include appliances being switched off under customer control. Another factor is believed to be poor RF communication between device and Hub within houses;

- With the number of DDSM devices out of communication rising during summer periods to around 50-60%, the theoretical wind generation that could be supported reduces from 385 to 230 MWh;
- A set of constraint rules has been set up to preserve stability of the Shetland network. When a large amount of renewable generations intends to access the network, the fast-acting SVT (Sullom Voe Terminal) generator has to release some load for high exports of non-firm distributed generation, i.e. ANM Controlled Generation (ACG). This may impact the minimum-take export limit of SVT and potentially activate the reverse power flow protection at SVT, which would lead to the curtailment of all ACGs. With the integration of a BESS on the network, the excess of renewable generation can be absorbed by the BESS so as to prevent the large reduction in SVT exports exceeding the limit, especially at times of low demand where the low SVT exports are close to the minimum limit;
- NINES demonstrated that it was possible to fully integrate a number of domestic properties with an ANM system capable of autonomously scheduling demand either at times where intermittent renewable generation would otherwise be constrained, or when demand was low. This has not only served to reduce peak demand on Shetland but has allowed a higher utilisation of renewable energy. Domestic properties have the potential to provide a useful source of demand side response for DNOs. There is significant roll out potential in the UK with over 2.2 million homes currently using electrical heating systems. This could provide significant benefits in balancing the GB network in future;
- The existing commercial arrangements with the DDSM, Shetland generators, and the large-scale VRLA battery contributed to supporting the secure and stable operation of Shetland network. The DDSM customers provide necessary flexibility by allowing shifting a portion of their load (i.e. storage and water heating) to reduce peak demand and renewable generation curtailment. These customers are engaged directly through 6 core methods, which are⁹: issue payments, website updates, hosting of local meetings, issuing of written communications, initiation of phone calls, and carrying out home visits. Shetland generators include conventional generators, 'must-take' renewable generators, and flexibly connected DGs. The conventional generators provide the resource of stability and security for Shetland power system. Renewable DGs commercial arrangements are based on LIFO, which defines an order in which their outputs can be curtailed when needed to maintain secure system operation.

The battery is operated by SSEN to help meet the needs of the Shetland network, by charging during periods of low demand and discharging during periods of high demand. A new control algorithm due to be implemented in 2017 will also take into consideration absorbing of available renewable energy, with an aim of reducing DGs' curtailment.

LO 2. What is the relationship between intermittent generation and responsive demand, including storage?

- Effectiveness of frequency response demand side management
- Maintaining network stability in an operational environment
- Interaction of numerous variables on a closed electrical system

The ANM platform provides a link between the intermittent generation and responsive demand. Operational experience has provided guidance as to how the ideal scenarios for maximising renewable generation and reducing demand peaks can be found. The project has proven that through active management the relationship between intermittent generation and demand can have a positive impact, and if supported with widespread DDSM and storage elements can help to address network issues such as voltage stability and frequency fluctuations.

- Frequency responsive DDSM has been shown to enable stable network operation in conjunction with an ANM system. We have shown that frequency responsive demand can be used to maintain the frequency stability of the system under the calculated limits.

Implementation of Frequency responsive demand in the Shetland network can increase the amount of renewable generation by two approaches:

- **DSM without using frequency response**
 - The use of flexible demand devices without using frequency response can increase the total system demand at certain times and therefore raise the maximum capacity for wind generation
 - when heating elements are fully charging in the 223 homes, the total maximum wind generation that is allowed to be connected can be increased by 212 kW.
- **DSM with frequency response (FR-DDSM)**
 - The second approach is to use the frequency responsive demand to maintain the frequency stability of the system under the calculated limits

In general, using FR-DDSM can allow more wind generation than DDSM without frequency response (DSM only when used to increase the demand). For example, the 1.639 MW of FR-DSM allows 1.36 MW of additional wind to be connected, which is higher than using DDSM alone (0.212 kW). The amount of additional wind that could be connected by using FR-DSM is about 6 times greater than that with DDSM only. The use of domestic demand to provide fast frequency response is practical and effective. Further details can be found in the *NINES Frequency Response Report 3A*⁷ and *3B*⁸;

- The battery analysis detailed in the *NINES Report 2A*⁶ shows the exports of intermittent generation connected via the NINES ANM are limited by constraint rules. The fast-acting SVT export will be reduced to accommodate high outputs from ACG, which may impact the minimum-take export limit of SVT. The BESS can help accommodate high ACG exports through absorbing the ACG power which would otherwise be curtailed. Though the manual schedule is not optimised for this, it has enabled around 52.7MWh of additional ACG export during the off-peak over the period from September 2015 to November 2016. With a large increase in ACG capacity and a new real-time algorithm developed by SSEN to charge the battery in response to ACG curtailment, the BESS will play an important role in promoting the utilisation of intermittent generation while preventing the trigger of reverse power flow protection at SVT.

LO 3. What is the economic impact on industry participants and other stakeholders of the low carbon operation of the network?

- NINES project spending in the Shetland Islands supported 17 person-years of employment on Shetland, over £1 million worth of economic output and £506,850 of the gross value added to the local economy;
- Lower domestic electricity consumption increased household income for the 223 households that were the total number of homes participating in NINES DDSM as at March 2017 by the equivalent of a total of £7,950 for each year of operation;
- The annual economic impact of this additional income on the Shetland economy is equivalent to £10,000 worth of economic output and additional employment of 0.2 persons per year;
- From the economics analysis, a total of 4.9% of the total NINES project budget was spent on Shetland, equivalent to £749,250.

LO 4. What new commercial arrangements are needed to support a low carbon network?

- The use of Flexible Solutions is subject to a large number of new risks associated with the interactions between the different economic and social drivers of public authorities and businesses. This results in a need for significant over-provision of flexibility in any given geographical area to achieve the optimal benefit;
- Following the advice of battery provider, the NINES VRLA battery was removed from service after an incident in January 2017. However, potential commercial arrangements could include the provision of flexible services on Shetland, so to smooth peak demand and reduce renewable generation curtailment. Such services could be contracted from a battery, owned and operated by a third party and could provide contracted services that would assist network balancing;
- Future participation of the NINES elements in the GB balancing mechanism market has also been considered, however it will require a suitable link between Shetland and GB mainland, and is, therefore, beyond the scope of the NINES project;
- To support a move to a low carbon network, areas which require further development include tariff structures, changes to the regulatory framework, development of ancillary market services and a market for domestic services.

The anticipated formal appointment of SSEN to the role of DSO will present the potential for a conflict of interest and a barrier to the DDSM market on Shetland however this could provide the opportunity to develop new commercial arrangements which allow aggregators to engage with domestic customers. SSEN could potentially carry out future tenders (such as CMZ or similar) on Shetland for services, which could provide a route for these parties to become involved.

LO 5. What is the impact of the low carbon network on domestic and industrial customers?

- **Effect on fuel poverty**
- **Changes in attitudes, awareness and behaviour amongst customers**
- **Extent of financial impact on participants**
 - Fuel poverty levels on Shetland have reduced in the latest data, with 52% of households living in fuel poverty (down from 53%, Scottish Government, 2017). Lower domestic electricity consumption increased household income for the 223 households by the equivalent of a total of £7,950 for each year of operation; NINES has contributed towards this overall reduction through installation of more efficient heating appliances;
 - NINES has more than trebled the volume of renewable generation on Shetland, taking the contracted renewable capacity to 12.5MW;
 - As of 24 March 2017, the amount of renewable energy brought on to the Shetland Network is 14.9GWh. It is predicted that this value will rise to 25.6GWh in 2017/18 following the connection of Garth Windfarm (4.5MW) which is the final renewable generator to connect to NINES. It is estimated that as a result of this, NINES connected wind will reduce fossil fuel generation and provided a reduction in CO₂ emissions from fossil fuels of 11.8%;
 - A principal intervention of the NINES project is to use DDSM technology at the household level to improve the management of the local electricity supply system. DDSM households were invited to complete survey feedback on their experiences. Of the nineteen surveys received, households' identified cheaper and more efficient energy through NINES;
 - Hjaltland Housing Association (HHA) contracted with Glen Dimplex to replace old off-peak storage heaters and hot water tanks with smart, DDSM compliant appliances. Customers were not asked to change behaviour and so the participation rate has been high, significantly more so than in demand-side response programs with variable pricing. Financial incentives were offered initially, but they were not needed to maintain participation through changes in tenancy;

- These new appliances are better insulated than those they replaced and they also provide the HHA tenants with more control over when the stored heat is used. Modelling studies show that, other things being equal, the new heaters should use 10-18% less energy to maintain the same room temperatures because they are able to take only the energy they will need and control the time when it is used. The benefits associated with these appliances can be taken either in terms of costs saving (reduction in energy used) or comfort (increased room temperatures);
- Recruitment of demand flexibility via a Housing Association was found to be relatively straightforward and cost effective. Learning from other trials such as New Thames Valley Vision Project have found that recruitment of private individuals has a higher effort per sign-up and a slower rate of recruitment, which adds considerable time and cost to the process;
- Analysis and experience during NINES shows that there are no significant energy bill differences between customers using prepayment metering arrangements and customers on standard credit metering arrangements. This indicates that demand flexibility for fuel poor customers can still be leveraged without negatively impacting this potentially vulnerable set of customers;
- The Quantum control system has been designed to prioritise the customer rather than the network, where appliances experienced communications problems this had no impact on customers;
- The grid-scale BESS at Lerwick Power Station was scheduled with a primary aim to discharge at peak times and charge at times of low demand, which smoothed the demand curve of the Shetland network. This led to more level power outputs and thus a more efficient operation of conventional generation units and a reduction in fuel consumption as well. Furthermore, at times the energy used to charge the BESS was from additional export of ACG which would otherwise be curtailed. When the real-time control algorithm is implemented, the energy absorbed by the BESS may be mainly supplied by ACG. The ACG export stored in the BESS will then be injected into the network at peak times to reduce the demand to be met by conventional generation. The time-shifting of conventional generation and intermittent generation enabled by the BESS will reduce fuel consumption and generation costs of conventional generation plants.

Furthermore, additional export of ACG enabled by the BESS which would otherwise be curtailed will increase the financial benefits to ACG owners.

LO 6. To what extent do the new arrangements:

- **Stimulate the development of, and connection to, the network of more renewable generation?**
- **Reduce the area's reliance on fossil fuels?**
 - Previously, without a form of controlling generation and responsive demand on the island, it was not possible to facilitate the connection of any new renewable generation due to stability and frequency constraints on the network. The deployment of ANM through NINES has more than trebled the volume of renewable generation on Shetland, taking the contracted renewable capacity to 12.5MW;
 - The ANM platform provides the capability to control generation in its current form. The system rules can be altered should future commercial arrangements change. Generation or storage capability can be added or removed from the system, ensuring flexibility for the future network;
 - The implementation of frequency responsive demand in the Shetland network can increase the amount of renewable generation that can be connected to the system by two approaches. The first approach is to time shift flexible demand at times that suit the network without using frequency response. Time shifting demand can raise the maximum capacity of wind generation that can be connected as presented in the previous section. As detailed in 3B NINES Frequency Response – Operational Effectiveness Report⁹, when heating elements are fully charging in the 223 homes, the total maximum wind generation that is allowed to be connected can be increased by 212 kW. The second approach is to use the frequency responsive demand (with the current settings) to maintain the frequency stability of the system within the limits. When heating elements are fully charging in the 223 homes, the total maximum wind generation that is allowed to be connected can be increased by 1.36MW which is about 6 times greater than that with DDSM only;

- In addition, the application of the DDSM scheme and the 1MW 3MWh battery have alleviated the renewable energy curtailment, thus the project succeeded in utilising more renewable energy and reducing conventional generation outputs. The flexible DDSM customers reduced 77MWh of renewable energy curtailment (26.14MWh generated by North Hoo and 50.87MWh generated by Luggie's Knowe) from February 2016 to January 2017. For the period from September 2015 to November 2016, the battery alleviated 52.7MWh of additional renewable generation outputs (18.1MWh at North Hoo and 34.6MWh at Luggie's Knowe). With Garth wind farm commissioned in March 2017, the DDSM flexible customers and the battery are expected to contribute to a greater amount of renewable energy curtailment reduction;
- The BESS may be able to accommodate high ACG export by absorbing additional ACG export which would otherwise be curtailed under the schedule of real-time control algorithm. When the total capacity of ACG on the network increases to the maximum value of 8.545MW, the advantage of the real-time algorithm in alleviating the ACG curtailment may be largely reflected. The ACG exports absorbed and stored by the BESS will be delivered back to the network at peak times subject to current levels of round-trip efficiency of just over 75%. The time-shifting of renewable generation achieved by the BESS will reduce the reliance on fossil fuels;
- As of 24 March 2017, the amount of renewable energy capable of generating on to the Shetland Network is 14.9GWh and it is predicted that this value will rise to 25.6GWh in 2017/18 following the connection of Garth windfarm (4.5MW) in March 2017;
- During the NINES project, emissions related to domestic electricity consumption have reduced with installation and integration of new renewable technologies that displaced some of the generation from conventional LPS. This in part contributed to a 16% reduction in emissions, which is the fastest annual decrease over the last decade. Such rapid improvement is also due to the fact that domestic electricity consumption on Shetland is higher than in many local authority areas, mainly due to a high share of properties using electricity to heat properties;

LO 7. What effect does the NINES project, and its legacy, have on Shetland's economy?

- University of Strathclyde has provided details in *6A NINES Commercial Arrangements and Economics Report*⁹ showing NINES project spending in the Shetland Islands supported 17 person-years of employment on Shetland, over £1 million of output and £506,850 of local gross value added;
- They have highlighted that lower domestic electricity consumption increased household income for the 223 households that were the total number of homes participating in NINES DDSM as at March 2017 by the equivalent of a total of £7,950 for each year of operation and that the annual economic impact of this additional income on the Shetland economy is equivalent to £10,000 of output and additional employment of 0.2 persons per year;
- Introduction of NINES has more than trebled the volume of renewable generation on Shetland, taking the contracted renewable capacity to 12.5MW;
- Fuel poverty levels on Shetland have reduced in the latest data, with 52% of households living in fuel poverty (down from 53%) .

LO 8. What effect does the NINES project, and its legacy, have on Shetland's carbon footprint?

- During the NINES project, emissions related to domestic electricity consumption have reduced with installation and integration of new renewable technologies that displaced some of the generation from conventional LPS. This led to a 16% reduction in emissions, which is the fastest annual decrease over the last decade. Such rapid improvement is also due to the fact that domestic electricity consumption on Shetland is higher than in many local authority areas, mainly due to a high share of properties using electricity to heat properties.
- Combining the reduced emissions from the consumption of electricity in domestic and industrial use on Shetland, DECC statistics reveal that between 2012 and 2015 there is a decline of 31.4 ktCO₂, which is equivalent to a reduction in CO₂ emissions of 10.9%.

- As of 24 March 2017, the amount of renewable energy brought on to the Shetland Network is 14.9GWh. It is predicted that this value will rise to 25.6GWh in 2017/18 following the connection of Garth Windfarm (4.5MW) which is the final renewable generator to connect to NINES. It is estimated that as a result of this, NINES connected wind will reduce fossil fuel generation and provided a reduction in CO₂ emissions from fossil fuels of 11.8%.

Project Structure

To divide the work into manageable sections, the research project was initially planned and then managed using themed Work Packages as follows:

- WP1 – the DDSM analysis, led by ESRU
- WP2 – the Battery analysis, led by EEE
- WP3 – the Frequency Responsive analysis, led by EEE
- WP4 – the ANM specification and performance, informed by SGS
- WP6 – the Commercial and Economic review, led by EEE and FAI

Each of these work packages generated one or more detailed technical reports, and interaction among the team members has resulted in useful additional areas of research being uncovered and explored. It soon became clear that most of these "Learning Outcomes" questions, as described in the previous section, required to be addressed from multiple viewpoints. A table correlating the detailed reports with the LO questions is included in the Appendix (2).

Relevance of NINES to other initiatives

Influence of NINES on New Energy Solution for Shetland

The Integrated Plan for Shetland was submitted to Ofgem on 31 July 2013. Following the submission of the Integrated Plan, Ofgem requested further information including a proposed Incentive Mechanism (IM) and Relevant Adjustment (RA) as required by CRC18A.11. SSEN submitted this to Ofgem on 23 December 2013.

This IM was subsequently rejected by Ofgem in a determination issued on 22 April 2014. This determination required SSEN to carry out various actions including the appointment of an independent auditor to oversee an open and public consultation and competitive tender process. Any proposed solution within the competitive process will have considered, and will integrate with any enduring elements of NINES. The bidders have been required to take the learning, progress and where applicable the outcome of NINES into account when developing their bids.

The tenders are currently under evaluation. Decisions on the outcome of this process are on schedule to take place by the end of 2017.

Work is underway to determine how the enduring component parts of NINES project should be treated in the context of the new energy solution. This is being undertaken with Ofgem, and will reflect feedback provided by bidders and existing NINES stakeholders as the competitive process develops. SSEN's current proposals are that the ANM system, the NINES generator queue and the battery are retained on an enduring basis, and that the ANM system is used to connect in and dispatch any future intermittent and storage services, and to offer "DSO" functionality.

Influence of NINES on Innovation Projects

The NINES Project is one of a whole portfolio of innovation projects SSEN are managing under LCNF, NIA, NIC, and other funding mechanisms. These can be broadly grouped into four key areas of development which are; *Safety, Health and Environment, Reliability and Availability, Connections and Capacity, Customer and Social Obligations*, and the ultimate aim of all of these projects is to save the customer money.

The chart opposite (Fig 1) shows the evolution of NINES as a project and also shows how NINES has already provided knowledge, learning and insight across a whole range of areas.

Early learning outputs from the NINES battery informed a number of other DNOs' energy storage projects including UKPN's Smarter Network Storage, and Northern Powergrid's Customer Led Network Revolution.

In particular, the learning around energy storage developed through this project led directly to the establishment of the Energy Storage Operators' Forum (ESOF). This is a forum whose membership comprises all of the GB DNOs and the Transmission System Operator. ESOF facilitates open and honest sharing of information and experience (including any failures or challenges encountered) between members on the practical aspects of Electrical Energy Storage systems through the whole project lifecycle. The learning from the batteries deployed in Shetland contributed two case studies to the ESOF Good Practice Guide on Electrical Energy Storage.

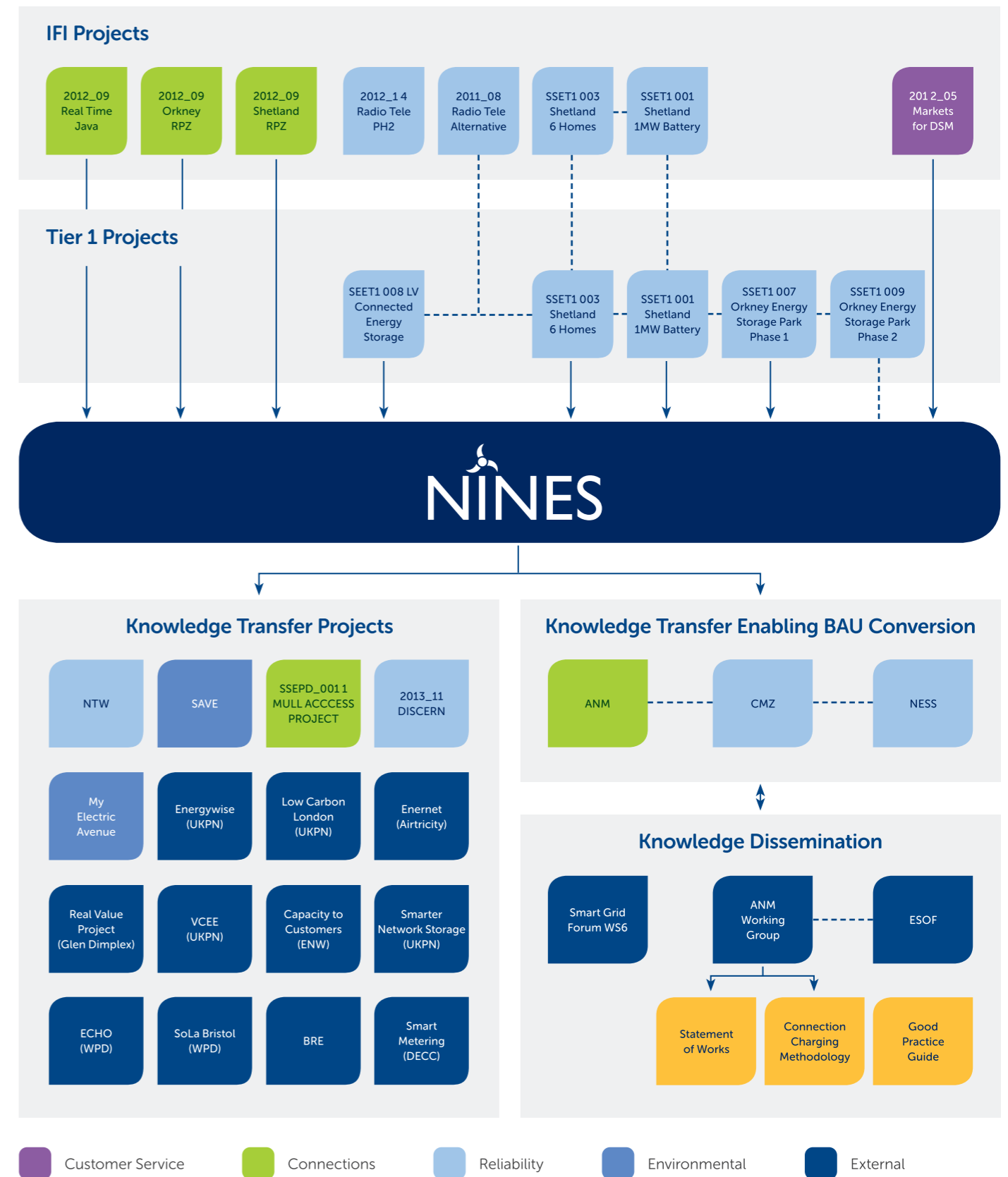

Figure 1: NINES in context of other projects

Modelling & Analysis contributing to Learning Outcomes

2. Modelling & Analysis contributing to Learning Outcomes

This section gives a brief description of the modelling & analysis approach. Details of the modelling tools are placed in the Appendix.

1. Infrastructure and Technology discussion
– elements of NINES and communications
2. Customer/Stakeholder discussion
3. Commercial Arrangements and Impact
4. Economic Impact
5. Operational and Network benefits

Infrastructure and Technology

NINES overview

The scope of the NINES Project evolved following the initial planning stage, and currently consists of the following major elements (see Figure 2):

Electricity Generation:

- Existing diesel-powered generators at Lerwick Power Station (owned and operated by SSE), Sullom Voe Terminal (gas turbine generator contracted to SSE via a Power Purchase agreement to supplement LPS), renewable generation at Burradale and Ollaberry (firm wind generator connections, totalling 3.84MW);
- New managed wind generation at North Hoo, Luggie's Knowe and Garth (totalling 8MW);
- New tidal generation at Cullivoe (which was a tidal test site, generating 50kW) and the larger Shetland Tidal Array (generating 500kW).

Controllable Demand:

- Domestic DDSM provided by controllable storage heaters and hot water cylinders in 223 houses;
- Battery system rated at 1MW, 3MWh (Lead-acid).

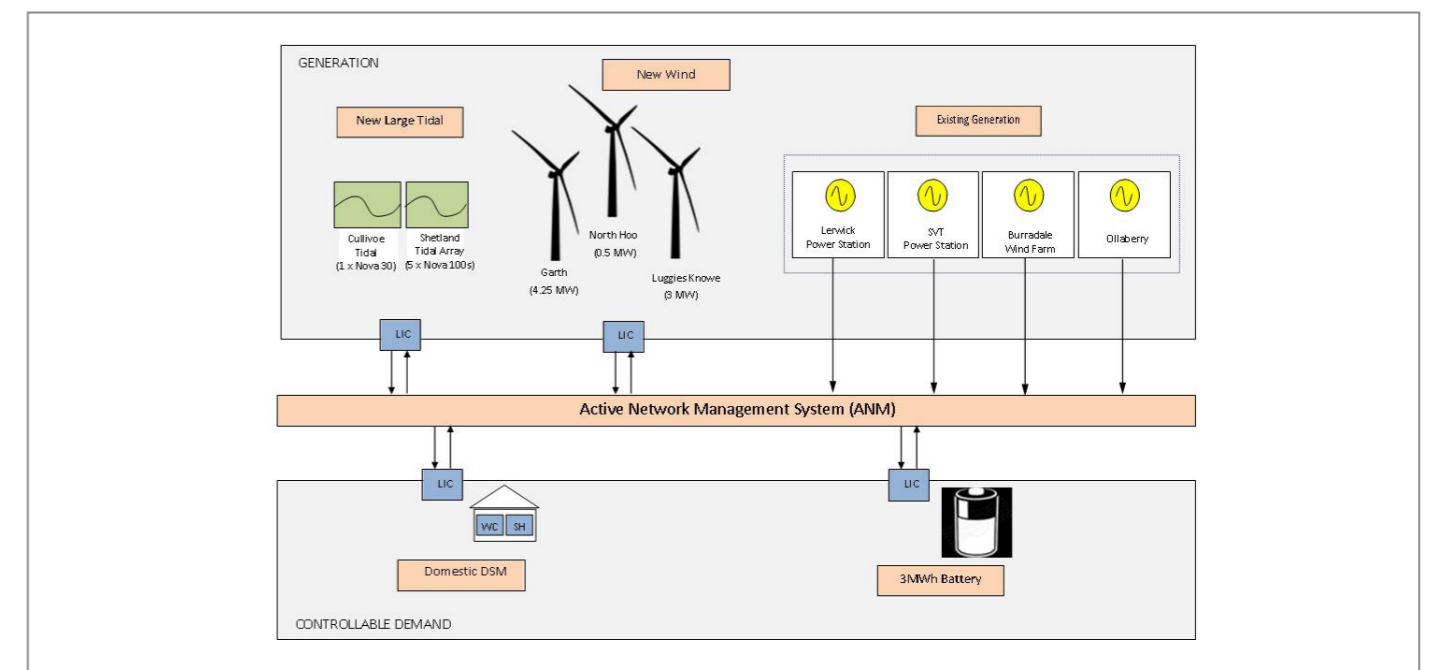

Figure 2: overview of NINES elements

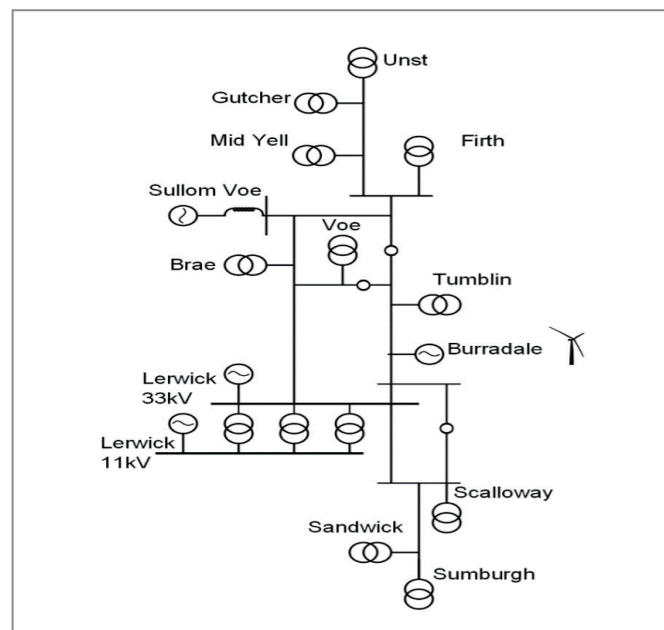

Figure 3: Schematic representation of the 33kV Shetland network

Control system:

- an ANM scheme, allowing connection of maximum possible renewable generation, providing network balancing, scheduling and enhancing the stability of the network.

Shetland 33kV Network

The isolated electrical network in Shetland consists of 33 kV overhead lines and undersea cables linking various islands together. The 33kV network is connected to a number of low voltage networks around Shetland. Figure 3: Schematic representation of the 33kV Shetland network is a single line diagram of the 33kV network in Shetland.

ANM overview

The ANM system is a real-time control solution that enables the co-ordination of the various elements of the NINES scheme and the Shetland system. Through active management of controllable network devices, the two high-level objectives of the NINES ANM system were to:

- Accommodate renewable generation customers thus reducing reliance on fossil fuels; and
- Smooth the demand curve to minimise peaks and troughs in Shetland system demand.

The ANM functional requirements cover three areas:

1. **Stability Constraint Management:** Where network devices, such as generators, responsive loads and energy storage devices, are controlled in real-time in response to prevailing network conditions. This meets the objective of accommodating additional customers while managing the network constraints that may arise following their connection;
2. **Device Scheduling:** Where forecasts are used to derive and issue schedules to appropriate devices to meet the objective of smoothing the demand curve;
3. **Configuration and Interface:** The requirements associated with ANM user interactions, the capability to issue manual control commands, and interfaces with other SSEN systems.

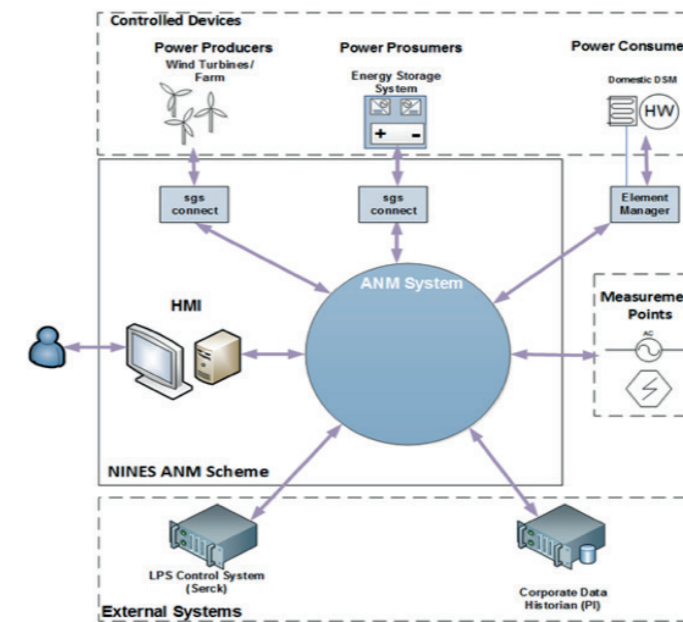

Figure 4: NINES ANM connections

The ANM system was developed to meet NINES requirements by establishing a real-time, deterministic control platform that hosted automated algorithms to monitor network parameters and control ANM elements including renewable generation, large-scale battery storage, and groups of domestic demand side management devices. The ANM platform built upon SSEN learning from the Orkney Smart Grid project, taking real-time constraint management beyond past demonstrations with multiple project partners, and collaborating to establish system constraint rules that define the autonomous management of new renewable generators against stability and operational constraints on the Shetland system.

DDSM overview

Following a review of potential flexible demand apparent within the Shetland housing stock, which reviewed appliance use vs consumption carried out by SSEN, space and water heating appliances were proven to be the appliances which offered the greatest potential effect on demand 'shifting' while still providing customers with the expected levels of comfort and control. SSEN engaged and worked with Glen Dimplex to produce a range of smart electric space and water heating appliances which were communications enabled for installation within the NINES project. SSEN worked with Hjalldland Housing Association and Glen Dimplex to install these advanced storage heating and water heating in 234 existing homes.

These new storage and water heaters (which replaced existing traditional storage heaters) were provided through Hjalldland Housing Association (HHA) and financed in part by ERDF funding and have been specifically designed to be compatible with flexible electrical charging arrangements. The charging arrangement used on NINES is determined based upon the predicted demand, weather forecasts, availability of renewables and other network constraints.

These energy storage appliances receive remote signals every 15 minutes, through the DDSM communication infrastructure, and allow a more flexible approach to charging. Figure 5 illustrates the infrastructure system of DDSM. This infrastructure includes a transceiver that is installed within each device and communicates with Dimplex Home Hub. The Home Hub is connected to a local interface controller (LIC) which is also located within the home. The LIC exchanges data between households (via the Home Hub) and the Element Manager (EM), with EM being responsible for aggregating and communicating data to the ANM control system at the Lerwick control centre. ANM system at the Lerwick centre, operated by SSEN, controls a signal sent between ANM and LIC. More detailed information on DDSM infrastructure can be found in IB NINES DSM Infrastructure Report.

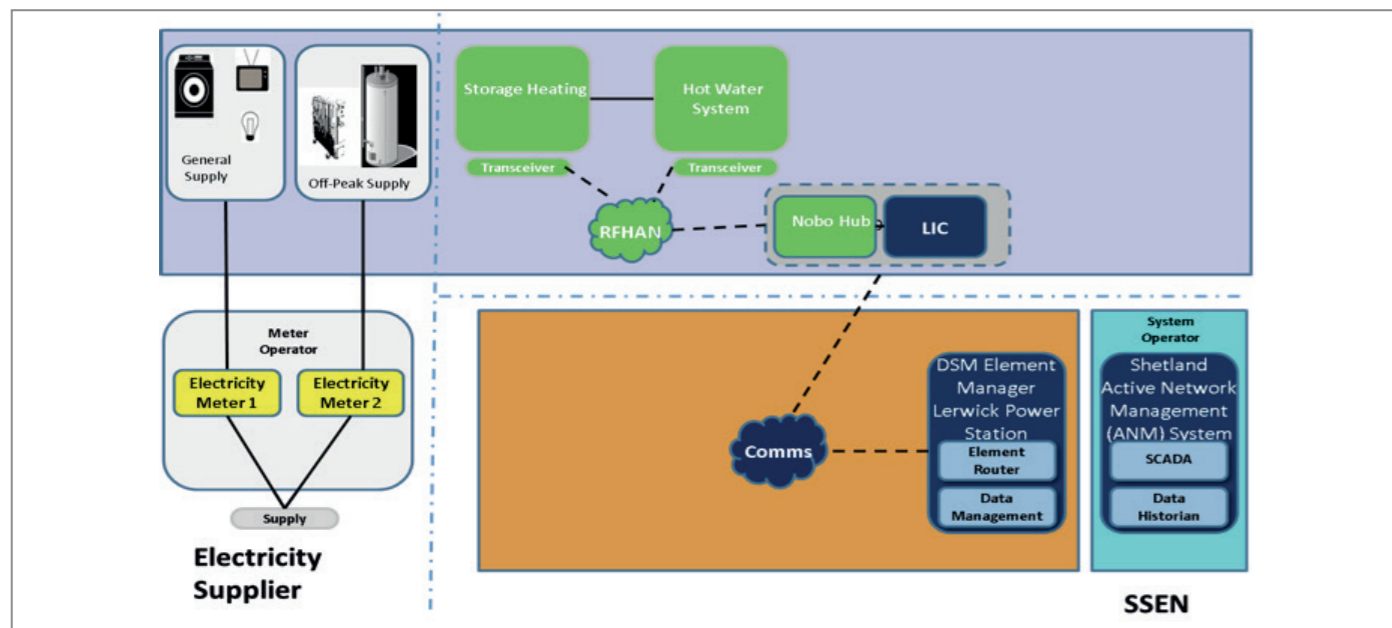

Figure 5: DDSM Infrastructure

The remote signals that the DDSM appliances receive instruct them when to charge, while also enabling them to send feedback information regarding their statuses, e.g. if they are charging, are on stand-by, switched off, etc. This communication and control allows the DDSM homes to provide capability for demand side management. In addition, the heating devices are frequency responsive, so that they can stop charging if the system frequency drops, or start charging if system frequency rises above the specified limits. Thus, the frequency responsive heaters can help the system operator maintain the balance between the demand and supply and therefore, maintain system frequency and security.

In addition to following signals sent through the ANM system, the appliances are also enabled to consider the comfort level of occupiers in the households. These DSM-capable devices are configured to be automatically switched off when room temperature is high and switched on when the room temperature reaches the minimum level, with the high and low temperature levels both set by the users. Based on the energy use during the previous day, and in order to ensure the different comfort level required by each participating DDSM household, an algorithm embedded within the heating devices calculates the Daily Energy Requirements (DER) for each device for the next day.

Battery Technology



Figure 6: Battery Installation

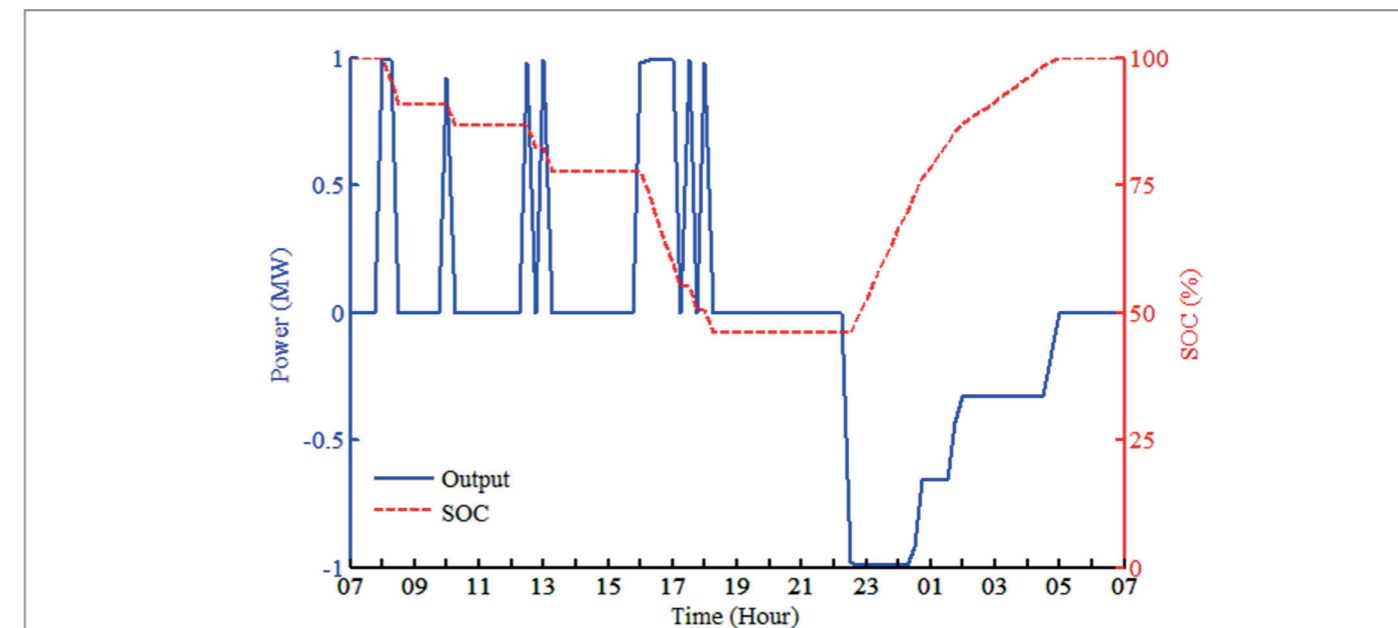

Figure 7: Power outputs (MW) of the 1MW, 3MWh BESS (charge rates are negative and discharge rates are positive) and corresponding variations in SOC (%) within a full cycle from 07:00 on 03/09/2014 to 07:00 on 04/09/2014

Following initial tendering and specification exercises with supplier S&C, installation of the original NaS battery was completed in September 2011. However, after an incident involving the same technology in Japan⁵, and after consideration of the risk assessment, SSEN concluded that due to safety concerns related to the location of this installation at LPS, NAS was no longer a suitable technology to be used on this project.

A 1MW/3MWh lead-acid battery was installed and commissioned at Lerwick Power Station in February 2014. The battery system is in part made up of 3,168 individual energy storage cells. The battery sought to help to optimise and stabilise the operation of the existing island network by helping to reduce demand peaks and fill demand troughs. Furthermore, the operation of the BESS also helped to facilitate the connection of 8.545MW of new renewable generation.

The daily discharge was limited to 3MWh in addition to a minimum 45% State of Charge (SOC). Twelve 15-minute discharge periods of 1MW were specified to coincide with peak demands each day. A higher energy requirement of 4MWh was required to recharge the battery back to its maximum SOC due to energy losses in a full cycle. When the SOC of the battery increased to 80% and 90%, an initial charge rate of 1MW reduced to 0.66MW and 0.33MW respectively, creating a step-down charging profile, as shown in Figure 7.

In February 2015, an important project milestone was reached with a further upgrade to the ANM which in turn allowed the scheduling of the battery to become fully automated. A continuous period of operation allowed SSEN to analyse the effectiveness of the rules around which the automated scheduling operates and SSEN worked closely with SGS to identify and deliver improvements and refinements to these rules. However, due to operational issues with the ANM system calculated schedules which had led to an unsatisfactory utilisation (47.2%) of the battery, scheduling was reverted to a manual schedule beyond June 2015. In the main, the battery was manually scheduled to discharge at peak times and charge at times of low demand. The 1MW, 3MWh battery energy storage system (BESS) had completed 288 cycles with a total export of 0.63GWh and a total import of 0.83GWh in the first full year from September 2014 to August 2015. Furthermore, the manually derived schedule had achieved a better utilisation (86.1%) of the battery during the first full year operation.

Considering operational issues with initial rules, an additional constraint rule was introduced beyond September 2015 to ensure that the SVT output was greater than the minimum-take export limit. Under the up-to-date rules, the export of ANM Controlled Generation (ACG) is limited to the rise of SVT output above the minimum-take export limit. The ACG export exceeding the ACG constraint would be curtailed. Charging the battery at off-peak times could alleviate the ACG constraint

and provide a certain headroom for additional ACG to generate. Though the manual schedule derived for the battery was not optimised for alleviating ACG curtailment, approximately 52.7MWh of energy used to charge the battery (i.e. 5.6% of the total import 0.94GWh) was supplied by additional ACG export which would otherwise be curtailed over the period from September 2015 to November 2016.

The total import and export of the BESS over more than two years from September 2014 to November 2016 were approximately 1.34GWh and 1.77GWh respectively, meaning a round-trip efficiency of 75.7% on average which was higher than an approximate efficiency of 75%.

Renewable Generation

The first renewable generator on Shetland was the privately owned Burradale wind farm (with installed capacity of 3.68MW), which was commissioned in 2000. It consists of three 660kW turbines installed in 2000, and two 850kW turbines added in 2003 Burradale wind farm is located in the centre of Shetland mainland, just a few miles outside of Lerwick, and is connected under a 'must-take' arrangement. The average capacity factor of Burradale is around 52%, which is very high compared to 20% which is typical for most European wind farms.

The Ollaberry wind farm was commissioned in 2014, and is located in the North mainland. This wind farm has a capacity of 180kW, with one 80kW and one 100kW turbine. The power output of the Ollaberry is also 'must-take'.

Prior to the NINES Project, despite the significant wind and tidal reserves on Shetland, it was not possible to increase connections of the renewable generation to the Shetland network. However, the NINES project has allowed connections and commissioning of additional renewable generators, with a total capacity of 8.545MW, via managed connections with access to the network controlled by the NINES ANM. These additional new renewable generators are:

- Cullivoe Tidal (45kW tidal turbine)
- Garth Windfarm (4.5MW)
- Luggie's Knowe Windfarm (3MW)
- Shetland Tidal (500kW)
- North Hoo, (500kW)

All of these generators are connected under flexible commercial arrangements, which means the power output can be curtailed according to the requirements of the Shetland network. The key to managing these conditions and ensuring generation is utilised wherever possible is the operation of the ANM.

The NINES managed renewable generators on Shetland are connected under flexible commercial arrangements with Last In First Off (LIFO) arrangement. This means that these generators can be curtailed when necessary to maintain secure system operation. For generators connected under LIFO arrangement, the last connected generator will be curtailed first. A stack position in LIFO order (i.e. the order of curtailment) is determined by the order of DG connection and is not affected by new additional generators which may be connected at a later date.

What was learned?

Commercial Arrangements

The DDSM scheme currently has 223 households participating, these homes are owned by HHA. The heating devices installed in the DDSM houses are remotely controlled and responsive to the signals sent through the ANM system. The 223 households are distributed on the Shetland Islands, with the majority 78% are in the centre and south of Shetland Mainland and the rest 22% located in North Mainland and North Islands. The DDSM customers were engaged directly in the NINES reports through 6 core methods, which are issue payments (as incentives for participation), website updates, hosting of local meetings, issuing of written communications, phone calls to customers, and carrying out of home visits.

The total cost of DDSM scheme and operational support during the project is £3.2 million, with the total ongoing operation support cost being £491k per annum after the end of the project. These costs are funded by SSEN and HHA, where SSEN contributed 64.8% of total DDSM costs during the project and providing 93.9% of ongoing operation support costs.

The commercial arrangements with the Shetland conventional generators, i.e. LPS and SVT, ensure the provision of the secure and stable operation on Shetland network. Since the New Energy Solution for Shetland tendering process is currently under evaluation, new commercial arrangement needs to be agreed between the potential asset owner(s) and SSEN (as the system operator on Shetland) to allow secure and stable network operation. The NINES project has enabled additional renewable capacity with the introduction of flexibly connected renewable DGs, including Cullivoe Tidal, Garth Windfarm, Luggie's Knowe Windfarm, Shetland Tidal, North

Hoo. The flexibly connected DGs are connected under LIFO arrangements, with generation onto the Shetland network being controlled by the ANM system. The Shetland network is a closed energy system, and the total generation output must replicate the islands' demand. The output of the renewable generators are subject to the commercial arrangements and also depend on the wind/tidal availability, as well as curtailment.

A 1MW 3MWh VRLA battery was installed on Shetland during the NINES project. In the period of operation from September 2014 to November 2016, the battery was cycled 612 times, with the total discharge power of 1.34GWh. Following the recommendation of the battery provider, the battery was removed from service in January 2017. The battery is owned and operated by SSEN on Shetland. During operation it sought to help to optimise and stabilise the operation of the existing island network by primarily helping to reduce demand peaks. It also helped to facilitate the connection of 8.545MW of new renewable generation. The battery production cost has been included within the LPS costs. The costs of the BESS are made up of two main components: the capital expenditure (CAPEX) that is the investment that activates the operation of the BESS; and the operational expenditure (OPEX) that is a continuous cost supporting the operation of the BESS. The capital cost of the battery was part funded by DECC via a Smart Grid Demonstration Capital Grant for £1.1m and £1m from Ofgem's Low Carbon Network Fund Tier 1. The remainder was funded through NINES and was operated by SSEN to help meet the needs of the Shetland network. As the one-time cost, CAPEX of the BESS is estimated to be approximately £3,974,000, including the investment in the storage unit, auxiliary system and other components that put the BESS into service.

The OPEX of the BESS includes the maintenance costs for battery and building, labour costs, etc. The biannual maintenance of the BESS unit was covered by the warranty provided by the battery's manufacturer which covered either a 5 year period beyond commissioning or until the battery reached 1,500 cycles, whichever came first. Within the warranty, the OPEX is evaluated to be £56,500 per annum. When 5 years or 1500 cycles are reached, the warranty could be extended at a cost of £18,500 per annum and the OPEX would increase to £75,000 per annum.

Possible future participation of the enduring NINES connected elements in the GB ancillary service market has been briefly summarised in *6A NINES Commercial Arrangements and Economics report*⁹, should the potential link between Shetland and GB mainland be realised.

Economic Impact

The total NINES project spending was £15.3 million, with £6.9 million related to staff costs and £8.4 million covering non-staff costs, i.e. equipment, IT, contractors and travel. The non-staff costs also include incentive payments made to each of the 234 households who were originally part of the scheme. 2.97% of staff costs and 6.48% of non-staff costs are spent locally on Shetland. Total spend on Shetland is 4.9% of the total project expenditure, equivalent to £749,250. The NINES project related expenditure of £749,250 added £1.023 million worth of economic output, £506,850 to the gross value added of the local economy, and raised employment by almost 17 person years of FTE employment over the project duration.

A principal intervention of the NINES project is to use DDSM technology at the household level to improve the management of the local electricity supply system. DDSM households were invited to complete survey feedback on their experiences. Of the nineteen surveys received, households' identified cheaper and more efficient energy through NINES. Thus, a long-term consequence of the change in households' electricity consumption has been considered based on the Shetland household electricity consumption data from The Department for Business, Energy and Industrial Strategy (BEIS). The latest 2014 – 2015 data reports indicated that median household electricity demand for Shetland customers on "economy 7" tariff fell by 1.9% between 2014 and 2015 (from 7,043kWh to 6,908kWh. The "economy 7" electricity consumption data is used as it is the most closely match with the form of contract used for the majority of households which saw interventions through NINES. The reduction in electricity spending increased 223 DDSM household income by £35 for each year of operation, i.e. a total of £7,950 for all affected customers per year. Moreover, the economic impact of the additional income on the Shetland economy is equivalent to the additional £10,000 worth of economic output, £5,150 to the gross value added of the local economy, as well as 0.2 person years of FTE employment per year.

Fuel poverty is particularly high for Shetland as electricity is used to heat homes in a high percentage of properties. The latest data show that Shetland is ranked 4th across the 32 local authority in Scotland, based on both measures on fuel poverty and extreme fuel poverty. However, based on the latest available data, fuel poverty level on Shetland was reduced, and fell from 53% to 52% of households living in fuel poverty.

Operational and Network Benefits

Alleviation of Renewable Energy Curtailment

Additional Renewable generation

- Under the up-to-date constraint rules, the increase in system demand through the utilising flexible DDSM or charging BESS would alleviate the constraint on ACG and allow additional ACG to generate if there was ACG curtailment.

The flexible DDSM was scheduled to alleviate the forecasted ACG curtailment in the order of daily energy requirement (DER) from largest to smallest. The remaining controllable demand was then used to fill demand troughs. It is estimated that around 77MWh renewable energy curtailment has been alleviated by DDSM groups (i.e. 26.1MWh at North Hoo and 50.9MWh at Luggie's Knowe), over the period from February 2016 to January 2017.

Under the current constraint rules, charging the battery at periods of low demand can increase the limit on ACG export. Though the manual schedule for the battery was not optimised for alleviating the ACG constraints, the charging periods that coincided with high ACG curtailment provided additional headroom for ACG to inject electricity into the network which would otherwise be curtailed. Over the period from September 2015 to November 2016, the total import of the BESS was 0.94GWh, where the charging allowed approximately 52.7MWh of additional ACG (i.e. 18.1MWh at North Hoo and 34.6MWh at Luggie's Knowe) to be delivered to the grid.

Additional benefits received by ACG owner for additional export

- The ACG owners could receive extra benefits for delivering additional ACG to the network through Feed-In Tariff (FIT): a 'generation tariff' which is a fixed price dependent on the type of distributed generator and installation size; and an 'export tariff' which is a bonus payment for surplus electricity put onto the network. The ACG could also decline the 'export tariff' and negotiate their own Power Purchase Agreements (PPAs) with electricity suppliers.
- Over a one-year period from February 2016 to January 2017, around 77MWh ACG curtailment has been alleviated by flexible DDSM. The payments for the additional export from North Hoo and Luggie's Knowe are evaluated to be £6,261.90 (i.e. £4,979.20 for generation tariff and £1,282.70 for export tariff) and £4,101.80 (i.e. £1,606.10 for generation tariff and £2,495.70 for export tariff) respectively.

- Over more than one year from September 2015 to November 2016, approximately 52.7MWh of reduction in ACG curtailment has been achieved by charging the BESS. North Hoo and Luggie's Knowe are estimated to receive £4,325.50 (i.e. £3,439.50 for generation tariff and £886 for export tariff) and £2,785.30 (i.e. £1,090.60 for generation tariff and £1,694.70 for export tariff) respectively.

Savings in conventional generation cost

- Meanwhile, the additional ACG export used to charge the flexible DDSM and BESS led to a saving in conventional generation cost. An estimated cost for conventional generation in Shetland in the period evaluated was £200/MWh, including all usage, spinning reserve, fuel and maintenance. The 77MWh of conventional generation displaced by ACG, over the period from February 2016 to January 2017, would therefore cost approximately £15,400, which was £5,036.30 higher than the total FIT payment estimated for the 77MWh additional ACG used by the flexible DDSM. The 52.7MWh ACG absorbed by the BESS would be converted into 39.5MWh of energy injected into the grid on the basis of an approximate 75% round-trip efficiency. (This is the 'time-shifting of ACG' enabled by the BESS.) The cost of 39.5MWh conventional generation displaced by additional ACG was evaluated to be £7,905 which was £794.29 higher than the total FIT payment for the additional ACG. Considering the electricity suppliers apportion the FIT costs to all their electricity customers, only the export rate is part of the Shetland costs. Therefore, the savings in conventional generation cost through the flexible DDSM and BESS absorbing the additional ACG were around £11,621.70 and £5,324.30 respectively over their respective periods under review. Furthermore, conventional generation being displaced by renewable energy reduces the fuel consumption.

In addition to the time-shifting of ACG enabled by the BESS, the conventional generation cost could be reduced by the time-shifting of conventional generation if there is a significant difference in the cost per unit of conventional generation between peak and off-peak times. That is, the conventional generation absorbed by the BESS during the off-peak period was at low prices. The energy stored in the BESS was then exported to the grid at peak times to reduce the demand to be met by conventional generation which would otherwise require a high cost. Provided that the BESS was operated at a 75% efficiency, the saving in conventional generation cost would be realised when the conventional generation cost at peak times was 1.33 times higher than that at off-peak times. This may be considered in the future arrangements. Furthermore, the smoothed demand curve would result in a more efficient operation of conventional generation units and thus a saving in fuel consumption.

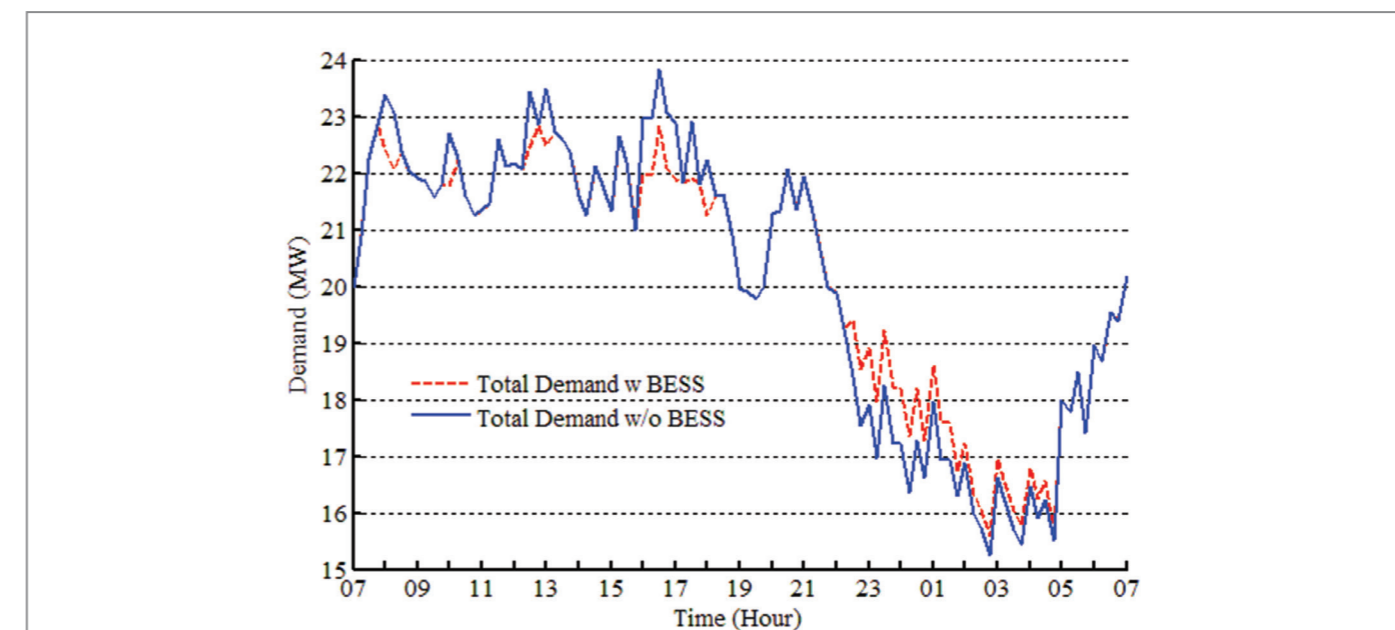

Figure 8: Total demand (MW) to be met by generators varying with the BESS's operation from 07:00 on 03/09/2014 to 07:00 on 04/09/2014

- As of 24 March 2017, the amount of renewable energy capable of generating on to the Shetland Network is 14.9GWh and it is predicted that this value will rise to 25.6GWh in 2017/18 following the connection of Garth windfarm (4.5MW) in March 2017. It is estimated that as a result of this, NINES connected wind will reduce fossil fuel generation and provided a reduction in CO2 emissions from fossil fuels of 11.8%. Therefore, this brings savings of almost £3m from the Shetland pass-through mechanism.

Load levelling

The primary role of the BESS is to smooth the demand curve on the Shetland network. For majority of its operation, the battery was manually scheduled to discharge at peak times to reduce peak demands to be met by conventional generation, and to charge during the off-peak periods which may increase the efficiency of lightly loaded engine sets at Lerwick Power Station. As an illustration, Figure 8 shows the variations (MW) in total system demand to be met by generators following the operation of the BESS that has been described in Figure 8.

In this 24-hour period, the maximum demand provided by generators was reduced from 23.86MW to 22.86MW by discharging the BESS at 1MW. The standard deviation of total export from generators decreased from 2.5MW to 2.1MW on that day, meaning that the demand curve on the Shetland network was largely smoothed. The grid-scale BESS has delivered 1.34GWh energy to the network at peak times and absorbed 1.77GWh energy at times of low demands in total over more than two years from September 2014 to November 2016.

As noted above, the primary role of the flexible DDSM groups is to alleviate the forecasted ACG curtailment. The secondary role was to smooth the demand curve through using the remaining DER to fill demand troughs. As shown in Figure 9, the flexible DDSM groups were usually scheduled to absorb energy during the night where system demand was at a low level. This would help increase the level of system demand during the off-peaks, smoothing the demand curve.

The non-firm ACG was more likely to be curtailed at the times of low demand. Though the controllable demand might be allocated at the wrong times to alleviate ACG curtailment due to the forecast accuracy and the use of constant SVT export, these controllable demand would contribute to load levelling if the 'wrong' times were determined as the moments of low system demand.

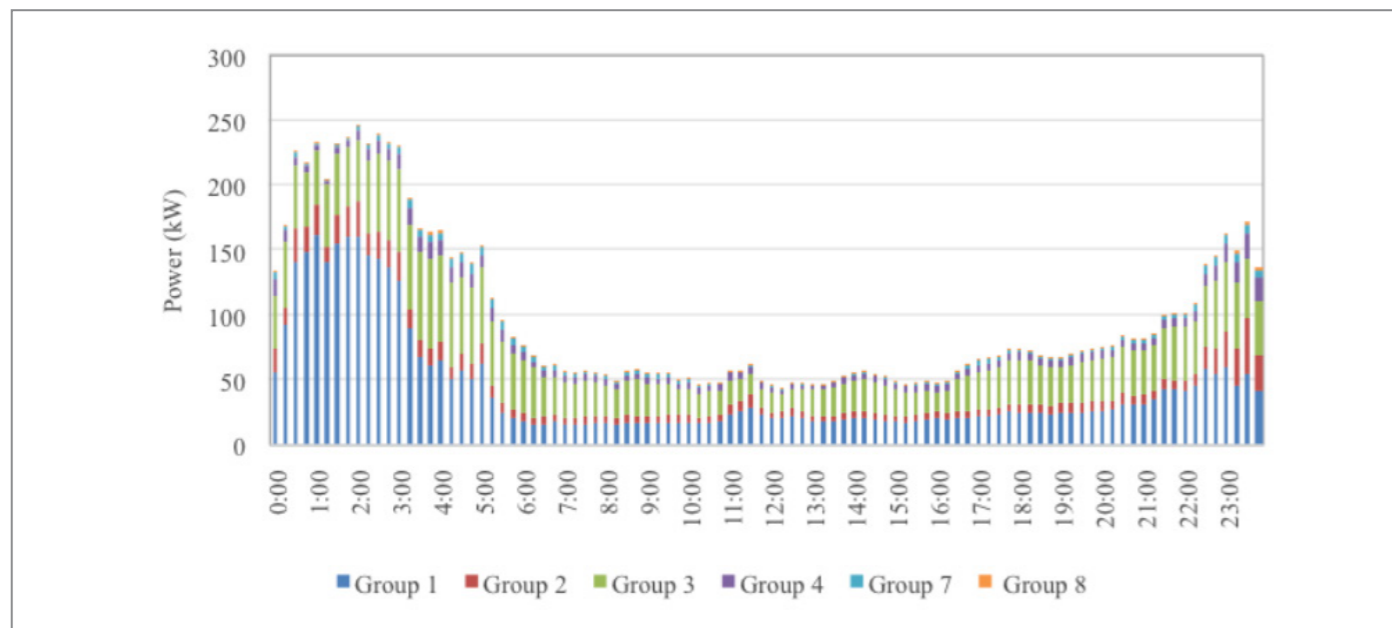

Figure 9: Average import (kW) of each flexible DDSM group per day over the year 2016/17

Frequency Stability

Frequency stability in the Shetland network is a major concern, as it forms an isolated system, which operates separately from the rest of the GB network. As the penetration of the wind generation increases, the possibility of a sudden loss of power from installed (and future) wind farms, due to either changes in wind conditions or in response to a network fault, would cause the network frequency to drift outside an acceptable range ($\pm 2\%$ of the nominal frequency).

Examining the security of the Shetland network against the loss of all wind generation is critical considering actual events observed on the Orkney distribution network. Historical records for several geographically separated wind farms on Shetland show events where wind generation varies by more than 90% of the installed capacity within 15 minutes at multiple wind farms. Examples of such a sudden change of wind generation output are shown in Figure 10, when there were large variations in power of a short timeframe. Therefore, a very important question arises for Shetland network: what is the maximum penetration level of renewable generation in Shetland network where it may still be operated in a safe, secure and reliable manner with respect to frequency stability?

To calculate a (theoretical) maximum penetration level of wind power, a number of simulations studies were conducted based on the dynamic modelling of most relevant components of the Shetland's power network as made available by SSEN. Simulations studies assessed dynamic performance of the network during different demand levels with a specified level of wind generation, then disconnecting the wind generation and allowing the system to respond. The frequency of the Shetland network and the export from SVT were monitored to ensure limits were maintained.

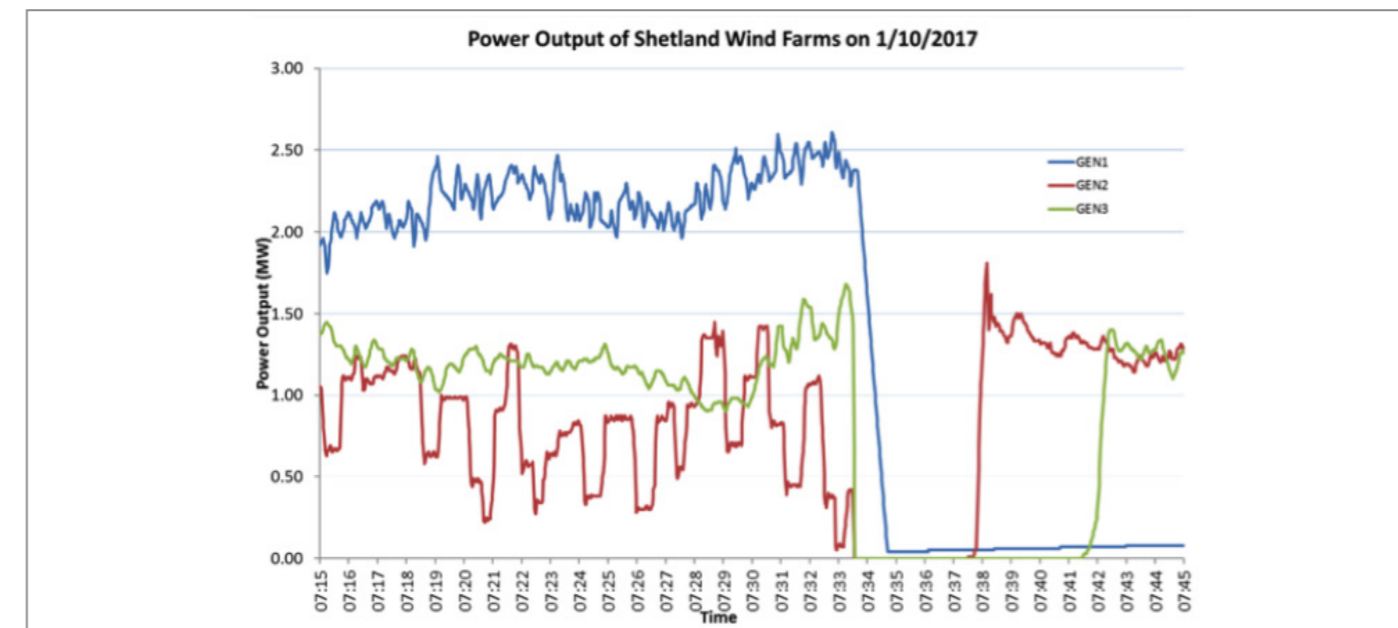

Figure 10: Power output (MW) of Shetland wind farms from 07:15 am to 07:45 am on 01/10/2017

To investigate the frequency response of Shetland network, two key scenarios are investigated: SVT offline and SVT online.

1. For the distribution system to be securely operated with a high penetration of wind generation, the maximum level of wind penetration has to be defined for each demand level. Two key scenarios were investigated which are the normal operation scenario when SVT is online and the critical scenario when SVT is offline;
2. The simulation results show that the theoretical maximum wind generation that could be connected when SVT is online is mainly limited by SVT circuit protection and voltage support rules. The results show that higher levels of wind generation are acceptable within the definition of frequency stability. However, the maximum wind generation that could be connected when SVT is offline, is limited by frequency stability.

These results are obtained for a unique specific generation dispatch as stated for each demand level as other dispatch may result in different values. Moreover, the simulated system frequency highly depends on the dynamic models used for the study which should imitate the behaviour of the equipment deployed on Shetland network. Power quality meters have to be installed in a number of locations in Shetland network to validate the existing module. However, the results can be used to identify the trends in network behaviour that would be seen with high penetration of wind power if the used dynamic models do not fully imitate the behaviour of the Shetland network equipment.

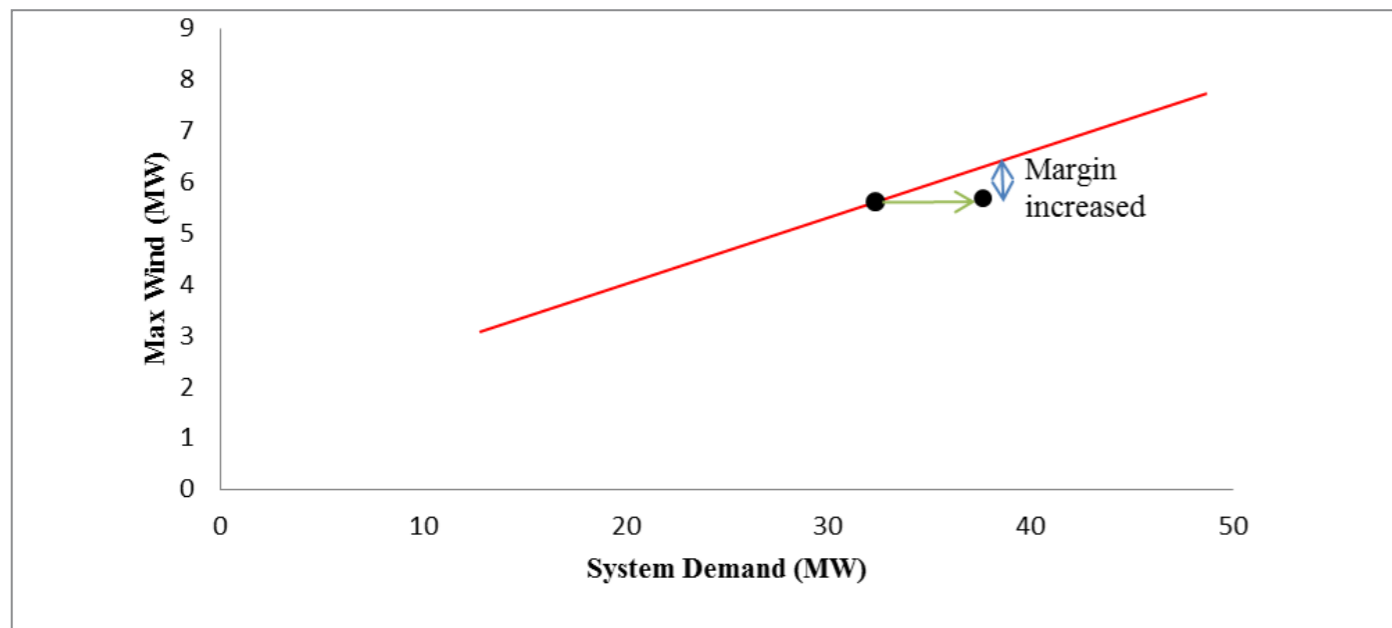

Figure 11: flexible demand and margin of stability

The implementation of frequency responsive demand in Shetland network can increase the amount of renewable generation that can be connected to the system by two approaches as explained below.

- **DSM without using frequency response**

The first approach is to control the responsive demand as to maintain the frequency stability of the system under the allowable limit whilst minimising wind curtailment. Although the maximum wind integration into the current Shetland power system when SVT is online is not constrained by frequency stability, it is limited by frequency stability when SVT is offline. Therefore, the use of flexible demand devices without using frequency response can increase the total system demand at certain times and therefore raise the maximum capacity for wind generation (see Figure 11- as the demand increment due to the DDSM could be met by additional wind power calculated according to the stability limit).

As the DDSM can increase the levels of intermittent generators by aligning demand with periods of wind curtailment, this requires adequate physical energy storage capacity, a control structure that allows for flexible delivery of energy.

The storage capacity of Glen Dimplex appliances used for space and water heaters could be available above that required to cover daily winter demand for space and water heating. Therefore, the appliances storage capacity would be available to accommodate additional wind power when required.

- **DSM with frequency response (FR-DSM)**

The second approach is to use the frequency responsive demand to maintain the frequency stability of the system under the calculated limits. Frequency responsive loads can vary their loading in response to a frequency disturbance according to predefined settings. In Shetland, 223 homes have been equipped with Dimplex space and water heating appliances that can be used to provide a frequency support. The appliances' controllers will measure the mains frequency and act accordingly if necessary. If the mains frequency drifts outside the dead-band then a modified power adjustment is calculated according to frequency variance outside dead-band and frequency response droop¹⁵.

To investigate the relationship between intermittent generation and the responsive demand used to support the system frequency, a user-defined model has been created to reflect the frequency responsive demand characteristic and the current setting.

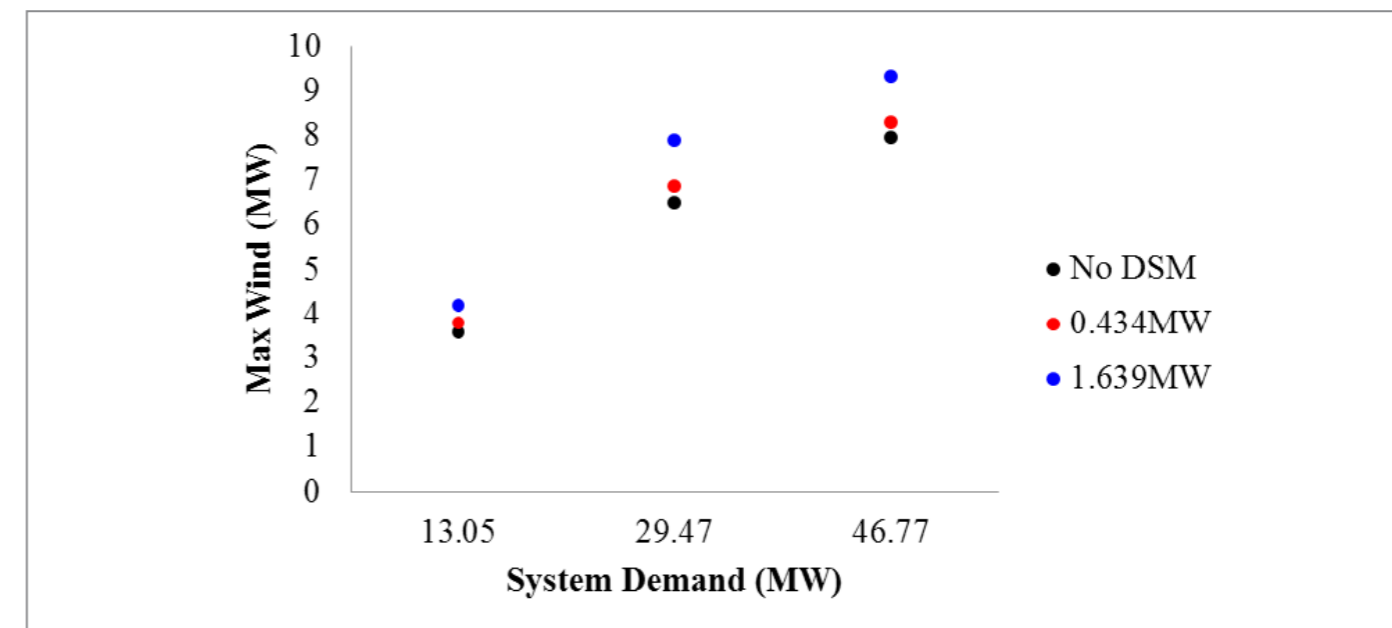

Figure 12: Maximum wind generation (SVT offline)

The responsive demand is modelled to replace the existing demand and is not modelled as an additional system demand. The time delay is estimated to be 350ms as an average value of the test conducted by Queens University Belfast. The current droop setting of the responsive demand is 500%/1 Hz with a dead-band of 0.3 Hz.

The previous simulation results for each demand level are summarised in Figure 12. These values are obtained by using a specific DDSM characteristic and settings. Other DDSM characteristic and settings may result in different values. Moreover, the availability of FR-DSM is playing a very important factor in supporting system frequency. FR-DSM can provide better frequency response during winter season when the availability of FR-DSM would be higher than the rest of the year. However, no frequency support could be gained by FR-DSM in summer as the availability is likely to be much reduced.

The amount of additional wind generation that could be connected for every 1 MW of available frequency responsive demand is different for each demand level and therefore it is difficult to get a linear equation. However, an estimation of a linear equation could be provided for two different demand levels.

According to Figure 12, the estimated linear relationship between the maximum amounts of wind generation that can be connected while FR-DSM is participating in frequency response can be written as:

For demands between minimum and average demand levels:

$$P_{wind}^{max} = 0.1293P_{Fixed\ demand} + 0.3701P_{FR-DSM} + 1.9135 - P_M$$

For demands between average and maximum demand levels:

$$P_{wind}^{max} = 0.1293P_{Fixed\ demand} + 0.8298P_{FR-DSM} + 1.8926 - P_M$$

Where $P_{Fixed\ demand}$ is the total system fixed demand, P_{FR-DSM} is the amount of FR-DSM participating in frequency response and P_M is an additional safety buffer between the calculated limit and operational limit.

Additional Learning Identified

The system frequency improvements provided by FR-DSM are highly depend on the availability of FR-DSM which varies during the day and through the year. The availability of FR-DSM during the summer is likely to be much reduced and hence little frequency support could be provided by FR-DSM. Moreover, for under-frequency events the FR-DSM is available only when the devices are on. The FR-DSM devices are usually charged during minimum load period after midnight. Therefore, FR-DSM might not be beneficial if there is an under-frequency event during peak period when there are no or a small number of the devices on.

The relationship between variables on Shetland's closed electrical system is complex and non-linear, so a dynamic simulation has to be used to establish the relation between these variables. A relationship between the frequency response of the Shetland system and the maximum wind generation as a function of total system demand is established. The maximum wind generation can be increase by using the DDSM to increase the total system demand at certain times without using its frequency response characteristic. For such an action, only part of the connected DDSM can be met by additional wind generation. The additional wind generation capacity can be calculated from the gradient of the frequency stability limit. As the DDSM and battery will be under the control of the network operators through the ANM system, network operators can use the DDSM without the provision of frequency response especially during low demand levels.

Prior to the commissioning of 4.5MW Garth wind farm, the 3.5MW ACG would not be curtailed at times when the system demand was still at a high level during the off-peak times. This is because the high SVT export led to the ACG limit being greater than the available power from the 3.5MW ACG even if the battery had not been charged. If similar cases occur, the real-time algorithm may not work to charge the battery when it is implemented to control the BESS. Fortunately, following the commissioning of 4.5MW Garth, the increase in total ACG capacity to 8.545MW will preserve the advantage of the real-time control algorithm in alleviating ACG curtailment at almost all times of the year.

Forecasting / Planning

NINES helped to develop additional algorithms allowing for real-time updates using ANM.

As noted above, charging the battery could alleviate the constraint on ACG under the present constraint rules. To facilitate the connection of ACG, a real-time algorithm has been developed by SSEN under the existing control architecture to operate the BESS. One of the objectives is to charge the battery in direct response to ACG curtailment. The charge rate of the BESS is determined by the real-time algorithm as the lower value of ACG curtailment and the maximum limit on the charge rate which depends on the SOC of the battery. Based on a series of historic data at times of low system demand where constraints on ACG were most prevalent, the real-time control algorithm was evaluated to charge the battery using the ACG export which would otherwise be curtailed.

3. Additional Learning Identified

Due to the collaborative nature of this project and the number of elements considered, it is not surprising that a number of areas of unanticipated learning have emerged.

Details of these additional learning points are as follows:

ANM

The trial of the ANM solution on the Shetland Isles has presented a great deal of learning for all project partners.

- One of the most significant learnings from the operation of the ANM system is that decisions made during the initial design phase of the trial to simplify the way the ANM platform operates, resulted in a lack of operability and control by the operators during more complex network operational situations. These limitations are being addressed through the implementation of an ANM platform upgrade which is due to be completed in 2017;
- The system was successful in controlling demand and generation, but there needed to be changes in the way in which the limits of the system were applied. The constraint rules were based on theoretical network studies and assumptions made in the early stages of the project (e.g. that LPS would supply a maximum of 40% of the demand) – in real-time operation this assumption was no longer valid due to the changes in operating regime at LPS and therefore, the constraint rules were no longer appropriate for the network. The constraint rules were adapted and additional ones created over the course of the project to manage these issues;
- Other changes such as a reduction in the size of the battery, and reduction in the number of DDSM homes resulted in less capability for the system to use responsive demand to support renewable generation and help minimise the peaks/troughs of the demand. Despite the reduced capacity of flexible demand the project managed to meet all expectations;
- As a result of the project, the ANM platform successfully communicates with all elements of NINES and demonstrates the ability to be flexible for future changes to the network;

- The project has identified the further ways in which the performance of the ANM platform can be improved in order to maximise available renewable resources, and help to reduce demand peaks and troughs. The final round of upgrades and re-configurations to the ANM platform, determined through the learning as part of this trial, due to take place in 2017 will ensure that the system is ready for changes which may arise in the future of the Shetland Islands electricity network;
- The ANM mainly schedules the flexible groups to charge between midnight and 5 am; on average, 75% of the day's demand is scheduled in that period. With only limited wind generation connected, overnight charging works best on most days to level demand on the power station.

DDSM

- Recruitment of demand flexibility is relatively straight forward and cost effective in relation to housing associations and councils as opposed to private individuals where the effort per customer sign-up and the slow rate of recruitment make the process non-viable for all but the slowest network demand changes;
- The underlying fixed costs (in particular communications) make small scale, low density demand side management uneconomic;
- The limited DDSM installed in 223 houses has delivered limited benefits to the network so far, but has resulted in much useful learning;
- The expected benefit from frequency responsive appliances were not fully realised because the main issue experienced on Shetland is with under-frequency events, where the DDSM devices need to be charging and switch off to contribute to network stability. Charging takes place over around 8 hours at most each day; and so far LPS has not relied on it operationally;

- Flexible charging uses a greater range of the physical storage capacity than fixed timing schedules. For space heaters the overall flexible range is between 20-60% of capacity in winter, falling to 20-40% in summer. For hot water tanks on flexible charging the range is 60-85%. The different control algorithms used by the two devices bias the space heaters to be working just above the minimum, and the hot water tanks to just under the maximum capacity;
- DDSM has had very little impact on control room operations; however, it has made a fundamental change in the network's relationship with customers as the DDSM service is the provision of heat and hot water rather than electricity. This has meant having to manage day to day relationships with many small customers to solve behavioural as well as technical problems. It also requires keeping track of a mass of detailed data;
- The maximum net value of each house to the DDSM supply chain is slightly less than £200 per year, plus the value to the network operator of 1-5 kW of flexible load and up to 8.2 kW of frequency responsive load. The net cost of each house to the supply chain is £330-£380 per year in communications and support services. All other costs and benefits are transfers within the supply chain. This model is not financially viable as it stands even with no customer loyalty or levelisation payments. Becoming viable requires an order of magnitude reduction in the communications costs, and/ or additional subsidy payments;
- The cost of using the DDSM heating devices to reduce the curtailment of renewable generation is determined by considering costs and levels of alleviated curtailment;
 - Based on the heater replacement programme information provided by HHA, it is assumed that the Dimplex heating devices (i.e. the storage heaters and hot water tanks) have a lifetime of 20 years. Under the assumption that the DDSM scheme will continue to operate on Shetland for that period, the lifetime total cost of the DDSM scheme is around £11.34 million;
 - The flexible DDSM customers helped alleviate 77MWh of renewable curtailment, in the period of February 2016 to January 2017;
 - From the above, the cost of alleviating the renewable curtailment through flexible DDSM would be £7,360.40/MWh;

- Moreover, on 26th September 2016, prepayment customers that were allocated to 6 (out of the 18) DDSM customer groups were moved into the flexible scheduling as it was identified that they could alleviate curtailment of renewables without adverse effects on their energy bills. Talking into consideration influence of these customers, would further reduce the value of £7,360.40/MWh to £5,364.75/MWh.

Renewable Generators

- The management of the timetable for connection to the network by renewable generators was entirely in the hands of the developers and the project had no influence over site progress. In all cases the impact of this was that renewable generators were connected to the NINES queue significantly later than the original intended connection date and this has materially impacted the amount of renewable generation on to the Shetland network over the project timeframe. It should be noted however that all of the generators have now connected and so the real legacy of NINES will be realised well beyond the lifetime of the project itself with future levels of renewable generation moving forward significantly increasing on those experienced to date;
- This is a success story for NINES. However, at times some of the generators remain materially constrained in part as a consequence of lower levels of storage than was originally envisaged being available. SSEN will require to consider how to manage these aspects in its work on the New Energy Solution for Shetland.

Battery

- Technology choice has been a key consideration throughout the course of the project;
- The original choice of a 1MW/6MWh NaS battery was innovative and bold however, for reasons outlined in this report and with the full agreement with Ofgem, it was decided to change technology to a 1MW/3MWh lead-acid. Due to levels of deteriorating performance the future of this battery system remains in doubt and it is expected that discussion around remediation will be on-going beyond the NINES project timescale;

- On 16 January 2017 an incident occurred whereby 2 cells were found to have failed. Investigations into the cause of this incident were carried out by SSEN, S&C Electric Ltd, the contractor chosen by S&C to supply and install the battery and ancillary systems, and Yuasa, a contractor to S&C who manufactured the battery cells. These investigations resulted in the identification of an additional 370 cells in various level of deteriorating charging capacity. Following the conclusion of these investigations, and at the recommendation of S&C Electric Ltd, the battery was removed from service;
- A new real-time algorithm has been developed to control the battery to absorb the surplus ACG export which would otherwise be curtailed. With the real-time algorithm and the increase in ACG capacity to 8.545MW, 1.2GWh energy used to charge the BESS could be supplied by ACG in a year if the battery is expected to complete 300 full cycles per annum.
- Following the commissioning of 4.5MW Garth wind farm, the ACG export absorbed by the BESS may be mainly from Garth and Luggie's Knowe due to the majority of access to the Shetland network is taken up by these two wind farms;
- Based on an approximate average rate of £75/MWh for Garth and Luggie's Knowe, the 1.2GWh ACG used to charge the BESS would cost £90,000 per annum. The 1.2GWh of absorbed ACG that would otherwise be curtailed could be converted into 0.9GWh energy delivered to the network at peak times, displacing the same amount of conventional generation which would otherwise cost £180,000. Therefore, approximately £90,000 would be saved per annum based on the BESS completing the expected 300 full cycles at a round-trip efficiency of 75%;
- EA Technology suggests that the life of the lead-acid battery is between 5 and 20 years. Considering a timeframe of 15 years, the total savings achieved by the time-shifting of ACG enabled by the BESS would be around £1.35 million (for 15 years), which may reach approximately 27% of the corresponding total project replication cost (i.e. £5 million). Detailed breakdown of the total project replication cost can be found in NINES Report 2A⁶;
- Based on the difference between the estimated total savings and projection replication costs in 15 years, and the volume of ACG curtailment that could be reduced by the BESS, the cost of using the 1MW, 3MWh BESS to alleviate ACG curtailment would be £203.14/MWh;
- Considering a forecast of 30.54% growth in the fuel price from 2016 to 2018 which is an important factor affecting the conventional generation cost, the savings achieved by the time-shifting of ACG would increase to £2.17 million and reaches 43.4% of the total projection replication cost at the end of the 15-year timeframe. In addition, the cost of using the BESS to alleviate renewable energy curtailment would reduce to £157.39/MWh.

Operational impact

Often the practical implementation of a design can highlight unforeseen issues, and NINES was not immune to these factors:

- The DDSM communication network was subject to software upgrades over the course of the project. Upgrades to the wide area network (WAN) were largely managed "over the air" resulting in minimal impact to customers as they would have been unaware that an upgrade was happening, however the Home Area Network (HAN) which was developed by Glen Dimplex did not have the facility to upgrade software "over the air". The impact of this was that where HAN upgrades were required each customer was visited in person by a Glen Dimplex authorised technician who performed the upgrade manually. Fortunately, instances of this nature only occurred once during the project and visits were managed and coordinated between SSEN, HHA and Glen Dimplex to minimise the impact to customers. Glen Dimplex has recognised and addressed this issue on subsequent projects;
- The nature of the complex relationships between partners meant that in some cases no formal contract existed between partners. This could have been problematic to the project delivery however due to the strong relationships between all partners this potential did not materialise
- SSEN had no control and limited influence over the build phase of each renewable generators' site, which affected planning of network and control updates;

The key learning from this outcome is to ensure that in future should remote monitoring and/or control equipment be located in customers' homes, this equipment should be specified with the ability of receive updates remotely.

- The nature of flexibility does not need to be constrained by Smart Meters in particular in relation to Fast Frequency response; this is not a capability of Smart Meters however the project has shown that the integration of logic into appliances can provide this service;

A key learning point from these experiences is that when engaging with third parties to provide energy storage facilities, it is better to ensure that there is an over subscription from third parties at an early stage so that any changes of a similar nature can be accommodated without significant impact to the intended levels of storage.

Despite these modifications, a significant amount of learning has been achieved, which remains relevant to the original Learning Objectives first outlined in 2011.

- The study on responsive demand penetration level shows that there is an optimal penetration level of frequency responsive demand when the incremental benefit of adding additional frequency responsive demand provides a declining benefit. The optimal penetration level of FR-DSM is highly depends on the used setting (dead-band and droop characteristic) and the system demand. The conducted study show that using 12% of the minimum demand as FR-DSM with the current setting can benefit the system frequency stability; however, increasing the FR-DSM beyond 12% of the minimum demand can lead to frequency stability problem if under-frequency events occur during minimum demand. Moreover, using 12% of the minimum demand as FR-DSM with higher droop characteristic might lead to stability problem if under-frequency events occur during minimum demand;
- Frequency responsive demand highly depends on the available system inertia. The amount of FR-DSM required to provide a similar response to one of the existing diesel machines at LPS increases as the total system inertia decreases. During peak demand a diesel machine with a rating of 4.6 MW connected at LPS can provide a comparable response to about 1.64 MW of FR-DSM. During minimum demand, about 2 MW of FR-DSM is needed to provide a similar response to the diesel machine. These results were obtained using the current FR-DSM settings as higher amount of FR-DSM would be needed if a lower droop characteristic is used. Moreover, a diesel machine provides a better frequency response as the rate-of-change-of-frequency decreases leading to improved system stability.

Dissemination activities

4. Dissemination activities

During the research and operational phase of NINES, opportunities to present aspects of the project at relevant conferences and industry events were taken wherever possible.

These included:

- LCNF conference
- All Energy conference

Summary of all NINES-related dissemination activities

Event	Date	Content / Key Message
OR54 Annual Conference	Sep 2012	Managing Projects In An Uncertain World: Engaging Stakeholders, And Building A Systemic View Of Risk – presentation by Fran Ackermann, Susan Howick, John Quigley, Lesley Walls and Tom Houghton
BRE Low Carbon Built Environment Seminar: The Future is Electric Heating, but is it Sustainable?	Sept 2012	Case Study: Home space and water heating aspects of the SSE Shetland NINES project – Katalin Svehla
ENA LCNF Conference 2012	Oct 2012	Interim outcomes and learning from six modelling focusing on the unit scheduling and dynamic models – presentation by Graham Ault
IEEE ISGT, Berlin	Oct 2012	Introduction to the interdependent system models in providing inputs to the active network management (ANM) design and configuration. Early results from model development and testing are presented with specific focus on the stability limits for the connection of additional renewable generation – Michael Dolan & Simon Gill
Community Energy Scotland conference	Nov 2012	Community impacts and benefits of the NINES approach – the potential – presentation by Stewart Reid
2012 ANZAM Conference, Perth Australia	Dec 2012	Presented paper – “Managing projects in an uncertain and volatile world: engaging stakeholders, and building a systemic view of risk” – Fran Ackermann

Risk Consortium (ManSci) event	Feb 2013	Presented overall view of NINES project – Tom Houghton
European Wind Energy Association Conference 2013, Vienna	Feb 2013	“Operating a Wind Farm in the Future Smart Grid”
Scottish Renewables, Edinburgh	18-19 March 2013	Panel discussion on energy storage at Grid Conference session – Stewart Reid
All Energy, Aberdeen	22-23 May 2013	Dedicated NINES session comprising several presentations – Stewart Reid
Renewable Energy World Europe Conference, Vienna	4-6 June 2013	Controllable domestic energy storage
CIREC 2013, Stockholm	10 – 13 June 2013	Building a framework for integrated risk management of complex projects: The case of a major distribution network investment – Tom Houghton. Modelling and Delivery of an Active Network Management Scheme for NINES – Simon Gill.
EURO 2013 (European Conference on Operational Research), Rome	1 – 4 July 2013	Managing Complex Projects for Industry: developing a new approach to risk management
BS2013 (13th International Conference of the International Building Performance Simulation Association)	Aug 2013	Electricity storage within the domestic sector as a means to enable renewable energy integration within existing electricity networks (J Clarke et al)
Regional Science Association international British and Irish Section Conference	Aug 2013	Impacts of NINES project on Local economy and electricity demand growth forecasting.
ESREL 2013 Annual Conference	29 Sep – 2 Oct 2013	Modelling Systemic Risks to Inform a Repowering Decision
Scottish Energy Systems Group (SESG) Seminars	Oct 2013	Presentations on DDSM context, methods and outcomes
Community Energy Scotland conference	Oct 2013	Community impacts and benefits of the NINES approach – lessons learned
IEEE Innovative Smart Grid Technologies conference Panel Session	Oct 2013	Panel session on Low carbon smart grids with 5-6 contributions from other similar initiatives including 2-3 on Shetland
12th Wind Integration Workshop	22-24 Oct 2013	Market systems for managing curtailment of wind generators
LCNF Conference 2013	Nov 2013	Final outcomes and learning from modelling activities

SSEN Future Networks conference (interim stage) – Scottish focus	1-day workshop	Integrated plan draft contents and outcomes of winter 2012/13 NINES trial results (DDSM, ANM, etc.)
SSEN Future Networks conference completion stage) – UK focus	1-day workshop	Wider implications of NINES trials on Shetland for: generation active management, domestic DSM, commercial demand, energy storage, ANM.
Webinar series	On-line	Various topics
Shetland stakeholders event	1-day workshop	Update on NINES developments
Training for SSE staff, Joe Clarke	9-13 September 2013	1-week module delivered as part of Power Plant Engineering course, included outline of NINES DDSM and findings (pros and cons) to date.
Energy Institute Annual Lecture, Glasgow, Joe Clarke	21 November 2013	External lecture NINES discussed under the heading of future energy options with smart grid
13th International Building Performance Simulation Conference, Chambéry, France Joe Clarke, Jon Hand, Jae-min Kim, Aizaz Samuel and Katalin Svehla	25-28 August 2013	Conference paper delivered Electricity storage within the domestic sector as a means to enable renewable energy integration within existing electricity networks
Back to the Future: a new life for storage heating? Katalin Svehla ESRU, with HHA, Dimplex, SSE	Half-day seminar, Tuesday 4th March, 2014	Target audience: Local council and housing association people; Scottish Government; Building services engineers; Scottish DNO and Ofgem people
‘Mainstreaming Innovation’ webinar ‘A bright future for storage heating’ 1-hour webinar hosted by UoS, Sponsored by Scottish Government (Ref: http://www.mainstreaminginnovation.org/content/webinars/213/)	21 March 2014	This seminar discussed how a new generation of storage heaters with better insulation and improved output control perform, both in stand-alone mode and when their charging is controlled by a smart grid. It included present outcomes from field trials of the technology in the Shetland NINES project as well as modelling studies.
Energy Storage Operators Forum (ESOF)	Shetland, 17 June 2014	NINES Project and Technical Visit:
2nd Conference on Building Simulation and Optimization, Joe Clarke, Simon Gill, Jon Hand, Jaemin Kim, Ivana Kockar, Aizaz Samuel and Katalin Svehla	London, 23-24 June 2014	Conference paper accepted The use of simulation to optimise scheduling of domestic electric storage heating within smart grids
European Lead Battery Conference	Edinburgh August 2014	Shetland battery

LCNI Conference	Aberdeen, 20-22 October 2014	Energy storage and demand side management
Ofgem WS6 Workshop	London, 13 October 2014	Energy storage and demand side management
Shetland Consultation Events	Shetland / Glasgow, November 2014	Public Consultations on potential new energy solutions for Shetland
Utility Week Conference	Birmingham, 22 April 2015	Making DDSM Happen – Working in New Ways
All-Energy Conference	Glasgow, 6 May 2015	Shetland An Energy Island – Demand Side Management of Customers
Ofgem Workshop	London, 6 October 2015	NINES – Working Heating Harder
IET – Distributed Generation 2015	Glasgow, 12 November 2015	NINES – A Case Study
LCNI Conference	Liverpool, 25 October 2015	The Impact of Frequency Responsive DDSM Equipment
LCNI Conference	Liverpool, 25 October 2015	Engagement in Innovation
LCNI Conference	Liverpool, 26 October 2015	NINES – Managing Change
New Energy Solution for Shetland Presentation to Bidders	Glasgow, 19th April 2016	Attendance at event
SHREC Conference	Inverness 21 April 2016	Update on Project Progress to date
All-Energy Conference	Glasgow, 5 May 2016	The Potential of Frequency Responsive DDSM Equipment
LCNI Conference	Manchester, 12 October 2016	NINES – Energy Storage and Network Management
2050 Scotland's Youth Climate Group workshop	Glasgow, 26 November 2016	NINES – Solutions for a Low Carbon Future
NINES and NTVV Event	London, 28-29 March 2017	Present NINES learning outcomes

NINES-related published papers

- Dolan, Ault, Frame, Gill, Kockar, Anaya-Lara, Galloway, Mathieson, Reid, Clifton, O'Neill, Foote, Svalovs, 'Northern Isles New Energy Solutions: Active Network Management Stability Limits', IEEE Innovative Smart Grid Technology Conference, (Berlin, October 2012).
- Ackermann F, Howick S, Walls L, Quigley J and Houghton T "Managing projects in an uncertain and volatile world: engaging stakeholders, and building a systemic view of risk" ANZAM (Perth, Australia 2012)
- Ackermann F, Howick S, Walls L, Quigley J and Houghton T "Managing projects in an uncertain world: engaging stakeholders, and building a systemic view of risk" OR54 (Edinburgh, UK 2012)
- Dolan, M. J., Gill, S., Ault, G. W., Barnacle, M., Foote, C., Bell, G: "Modelling and Delivery of an Active Network Management Scheme for the Northern Isles New Energy Solutions", CIRED – (Stockholm, June 2013)
- Houghton T, Ackermann F, Howick S, Quigley J and Walls L "Building a framework for integrated risk management of complex projects: The case of a major distribution network investment", CIRED (Stockholm, Sweden 2013)
- Walls L Quigley J Houghton T, Howick S and Ackermann F "Modelling Systemic Risks to Inform a Repowering Decision" ESREL (Amsterdam, Netherlands 2013)
- Ackermann F, Howick S, Walls L, Quigley J and Houghton T "Managing Complex Projects for Industry: developing a new approach to risk management" EURO 2013 (Rome, Italy 2013)
- Clarke, J; Hand, J; Kim, J; Samuel, A; Svehla, K: "Modelling electricity storage within the domestic sector as a means of enabling renewable energy integration within existing electrical networks". Building Simulation 2013, (Chambery, France, 26-28 August 2013)
- G.S. Hawker, L. Kane, K.R.W. Bell, "Wind Power Plant Behaviour in a Pay-as-bid Curtailment Market", 12th International Workshop on Large-Scale Integration of Wind Power into Power Systems as well as on Transmission Networks for Offshore Wind Power Plants, (London, October 2013)
- Simon Gill, Ivana Kockar and Graham Ault "Dynamic optimal power flow for active distribution networks". IEEE Transactions on Power Systems, 29 (1). pp. 121-131.
- Graham Ault, Joe Clarke, Simon Gill, Jon Hand, Jaemin Kim, Ivana Kockar, Aizaz Samuel and Katalin Svehla, "THE USE OF SIMULATION TO OPTIMISE SCHEDULING OF DOMESTIC ELECTRIC STORAGE HEATING WITHIN SMART GRIDS" Building Simulation and Optimization Conference BSO14, (London, June 2014)
- Simon Gill, "Maximising the benefit of distributed wind generation through intertemporal Active Network Management", Ph.D. Thesis (University of Strathclyde, Glasgow, March 2014)
- Mohamed Edrah, Olimpo Anaya-Lara, Ivana Kockar, George Bell, Stevie Adams, Fraser MacIntyre, "Impact of Domestic Responsive Demand on the Shetland Isles' Network Frequency Stability", 24th International Conference & Exhibition on Electricity Distribution, (Glasgow, June 2017)

Conclusions and main recommendations

5. Conclusions and main recommendations

1. *The availability of FR-DSM is an important issue especially for under-frequency events, where the FR-DSM devices need to be charging to contribute to network frequency. Therefore, FR-DSM will not be beneficial if there is an under-frequency event during peak demand periods when there are no devices charging*

The system frequency improvements provided by FR-DSM are highly depend on the availability of FR-DSM which varies during the day and through the year. The availability of FR-DSM during the summer is likely to be much reduced and hence little frequency support could be provided by FR-DSM. Moreover, for under-frequency events the FR-DSM is available only when the devices are on. The FR-DSM devices are usually charged during minimum load period after midnight. Therefore, FR-DSM might not be beneficial if there is an under-frequency event during peak period when there are no or a small number of the devices on.

2. *A generalised linear relationship was derived for the frequency constraint to determine the maximum amount of wind generation that could be connected for various demand levels.*

The relationship between variables on Shetland's closed electrical system is complex and non-linear, so a dynamic simulation has to be used to establish the relation between these variables. A relationship between the frequency response of the Shetland system and the maximum wind generation as a function of total system demand is established. The maximum wind generation can be increase by using the DDSM to increase the total system demand at certain times without using its frequency response characteristic. For such an action, only part of the connected DDSM can be met by additional wind generation. The additional wind generation capacity can be calculated from the gradient of the frequency stability limit. As the DDSM and the BESS will be under the control of the network operators through the ANM system, network operators can use the DDSM without the provision of frequency response especially during low demand levels.

The amount of additional wind generation that could be connected for every 1 MW of available frequency responsive demand is different for each demand level and therefore it is difficult to get a linear equation. However, an estimation of a linear equation could be provided for two different demand levels. The estimated linear relationship between the maximum amounts of wind generation that can be connected while FR-DSM is participating in frequency response can be written as:

For demands between minimum and average demand levels:

$$P_{wind}^{max} = 0.1293P_{Fixed\ demand} + 0.3701P_{FR-DSM} + 1.9135 - P_M$$

For demands between average and maximum demand levels:

$$P_{wind}^{max} = 0.1293P_{Fixed\ demand} + 0.8298P_{FR-DSM} + 1.8926 - P_M$$

Where $P_{Fixed\ demand}$ is the total system fixed demand, P_{FR-DSM} is the amount of FR-DSM participating in frequency response and P_M is an additional safety buffer between the calculated limit and operational limit.

3. *When SVT units are online, simulation results show that high levels of wind generation could be connected within the definition of frequency stability. However, the maximum amount of connected wind is limited by SVT circuit protection, voltage support rules, and SVT export limits.*

A set of constraint rules has been set up to preserve stability of the Shetland network. When a large amount of renewable generation intends to access the network, the fast-acting SVT generator has to release some load for high exports of non-firm distributed generation, i.e. ANM Controlled Generation (ACG). This may violate the minimum-take export limit of SVT and activate the reverse power flow protection at SVT, which would lead to the curtailment of all ACGs. With the integration of a BESS on the network, the excess of renewable generation can be absorbed by the BESS so as to prevent the large reduction in SVT exports exceeding the limit, especially at times of low demand where the low SVT exports are close to the minimum limit.

4. *The implementation of FR-DSM in the Shetland network can increase the amount of renewable generation that can be connected to the system by two approaches.*

The implementation of frequency responsive demand in Shetland network can increase the amount of renewable generation that can be connected to the system by two approaches as explained below.

- **DSM without using frequency response**
The first approach is to control the responsive demand as to maintain the frequency stability of the system under the allowable limit whilst minimising wind curtailment. Although the maximum wind integration into the current Shetland power system when SVT is online is not constrained by frequency stability, it is limited by frequency stability when

SVT is offline. Therefore, the use of flexible demand devices without using frequency response can increase the total system demand at certain times and therefore raise the maximum capacity for wind generation (as the demand increment due to DDSM could be met by additional wind power calculated according to the stability limit).

As DDSM can increase the levels of intermittent generators by aligning demand with periods of wind curtailment, this requires adequate physical energy storage capacity, a control structure that allows for flexible delivery of energy. The storage capacity of Glen Dimplex appliances used for space and water heaters could be available above that required to cover daily winter demand for space and water heating. Therefore, the appliances storage capacity would be available to accommodate additional wind power when required.

- **DDSM with frequency response (FR-DSM)**

The second approach is to use the frequency responsive demand to maintain the frequency stability of the system under the calculated limits. Frequency responsive loads can vary their loading in response to a frequency disturbance according to predefined settings. In Shetland, 234 homes have been equipped with Dimplex space and water heating appliances that can be used to provide a frequency support. The appliances' controllers will measure the mains frequency and act accordingly if necessary. If the mains frequency drifts outside the dead-band then a modified power adjustment is calculated according to frequency variance outside dead-band and frequency response droop²⁰.

To investigate the relationship between intermittent generation and the responsive demand used to support the system frequency, a user-defined model has been created to reflect the frequency responsive demand characteristic and the current setting. The responsive demand is modelled to replace the existing demand and is not modelled as an additional system demand. The time delay is estimated to be 350ms as an average value of the test conducted by Queens University Belfast. The current droop setting of the responsive demand is 500%/1 Hz with a dead-band of 0.3 Hz.

Note that different DDSM characteristic and settings may result in different values. Moreover, the availability of FR-DSM is playing a very important factor in supporting system frequency. FR-DSM can provide better frequency response during winter

season when the availability of FR-DSM would be higher than the rest of the year. However, no frequency support could be gained by FR-DSM in summer as the availability is likely to be much reduced.

5. *System frequency recovers better when a tighter dead-band is used with a higher droop. However, the amount of FR-DSM that can participate in frequency response is limited when a high droop is used. There is a FR-DSM penetration level where the frequency stability of the system starts to degrade.*

The study on responsive demand penetration level shows that there is an optimal penetration level of frequency responsive demand when the incremental benefit of adding additional frequency responsive demand provides a declining benefit. The optimal penetration level of FR-DSM is highly dependent on the used setting (dead-band and droop characteristic) and the system demand. The conducted study show that using 12% of the minimum demand as FR-DSM with the current setting can benefit the system frequency stability; however, increasing the FR-DSM beyond 12% of the minimum demand can lead to frequency stability problems if under-frequency events occur during minimum demand. Moreover, using 12% of the minimum demand as FR-DSM with higher droop characteristic might lead to stability problem if under-frequency events occur during minimum demand.

6. *The equivalent size of a diesel generator required to provide the same response to FR-DSM highly depends on the system inertia. The system inertia can vary depending on the system load and which generator is online*

Frequency responsive demand highly depends on the available system inertia. The amount of FR-DSM required to provide a similar response to one of the existing diesel machines at LPS increases as the total system inertia decreases. During peak demand a diesel machine with a rating of 4.6 MW connected at LPS can provide a comparable response to about 1.64 MW of FR-DSM. During minimum demand, about 2 MW of FR-DSM is needed to provide a similar response to the diesel machine. These results were obtained using the current FR-DSM settings as higher amount of FR-DSM would be needed if a lower droop characteristic is used. Moreover, a diesel machine provides a better frequency response as the rate-of-change-of-frequency decreases leading to improved system stability.

6. Appendices

1. Modelling Approach

The NINES research work streams employed various Modelling tools and techniques, some of which were developed specifically for the NINES project and might be used effectively in other projects.

Dynamic Optimal Power Flow Model

Active Network Management is a philosophy for the operation of distribution networks with high penetrations of renewable distributed generation. Technologies such as energy storage and flexible demand are now beginning to be included in ANM schemes. Optimizing the operation of these schemes requires consideration of inter-temporal linkages as well as network power flow effects. Network effects are included in Optimal Power Flow (OPF) solutions but this only optimizes for a single point in time. Dynamic Optimal Power Flow (DOPF) is an extension of OPF to cover multiple time periods. A published paper reviews the generic formulation of Dynamic Optimal Power Flow before developing a framework for modeling energy technologies with inter-temporal characteristics in an ANM context. The framework includes the optimization of non-firm connected generation, Principles of Access for non-firm generators, energy storage and flexible demand. Two objectives based on maximizing export and revenue are developed and a case study is used to illustrate the technique. Results show that DOPF is able to successfully schedule these energy technologies. DOPF schedules energy storage and flexible demand to reduce generator curtailment significantly in the case study. Finally the role of DOPF in analyzing ANM schemes is discussed with reference to extending the optimization framework to include other technologies and objectives.

Domestic Demand Forecast Model

The elements of the DDSM network were modelled in detail, allowing accurate simulation of the performance of the houses, Quantum heaters and hot water cylinders. ESP-r is the modelling system used by ESRU, which is based on an open-source tool for building performance simulation. It allows an in-depth appraisal of the factors which influence the energy and environmental performance of buildings. The ESP-r system has been the subject of sustained developments since 1974 with the objective of simulating building performance in a manner that: a) is realistic and adheres closely to actual physical systems, b) supports early-through-detailed design stage appraisals, and c) enables integrated performance assessments in which no single issue is unduly prominent. ESP-r attempts to simulate the real world as rigorously as possible and to a level which is consistent with current best practice. By addressing all aspects simultaneously, ESP-r allows the designer to explore the complex relationships between a building's form, fabric, air flow, plant and control. ESP-r is based on a finite volume, conservation approach in which a problem (specified in terms

of geometry, construction, operation, leakage distribution, etc.) is transformed into a set of conservation equations (for energy, mass, momentum, etc.) which are then integrated at successive time-steps in response to climate, occupant and control system influences. ESP-r comprises a central Project Manager around which are arranged support databases, a simulator, various performance assessment tools and a variety of third party applications for CAD, visualisation and report generation.

Power System Dynamic Model

The conducted study and scenarios are based on the dynamic modelling of most relevant components of the Shetland's power network, and test possible disturbances that have an effect on system frequency to provide an understanding on how FR-DSM can contribute to the secure operation of the Shetland's network with high penetration of wind generation. Moreover, a dynamic user-defined model is created to reflect the physical characteristic of the connected frequency responsive appliances in Shetland network.

GIS Mapping Tool

A mapping tool has been developed for SSEN to identify those domestic properties participating in the NINES project, and those which are not. The development process involved close collaboration between project leaders in SSEN and technical experts within ESRU; this depth of expert input and review gives the tool credibility. It was implemented as an interactive Geographic Information System (GIS) element, running on a freely downloadable application (QGIS).

Input-Output Analysis

When assessing economic impact the most widely used technique is Input-Output (IO) analysis, which utilises the information contained in IO tables (also referred to as IO accounts). Economic input-output tables provide a complete picture of the flows of goods and services (products) in an economy in a given year. These detail the relationship between producers and consumers and track the interdependencies of industries, identified using Standard Industrial Classifications. They are constructed directly from survey and other data sources and provide an accurate and comprehensive picture of an economy. These accounts can be used to derive "multipliers", which are shorthand measures of the extent to which the whole economy, and sectors within that, would be affected by exogenous changes, such as a change in demands for the output of individual sector(s).

2. Source Documents for the LO Questions

Report Reference	Report Title	Visit
1A	DSM: Customer Impact	http://www.ninessmartgrid.co.uk/learningandpublications/
1B	DSM: Infrastructure	As above
1C	DSM: Network Benefits	As above
2A	Battery: Operational Effectiveness	As above
3A	Frequency Response: Customer Impact	As above
3B	Frequency Response: Operational Effectiveness	As above
4A	ANM: Infrastructure & Communications Report	As above
4B	ANM: Operational Effectiveness	As above
6A	Commercial Arrangements and Economics Report (consolidated)	As above

Cross-reference detailed NINES source reports to address the LO questions below	WP1 DDSM	WP2 Battery	WP3 Freq Resp	WP4 ANM	WP5 Economics WP6 Commercial
LO1 – secure operation with high renewables?	1B, 1C	2A	3B	4A	6A
LO2 – intermittent generation vs responsive demand?	1C	2A	3B	4B	
LO3 – economic impact on stakeholders?	1A		3A		6A
LO4 – what new commercial arrangements needed?					6A
LO5 – impact of low carbon network on customers?	1A	2A	3A, 3B		6A
LO6 – how far renewable generation stimulated?	1C	2A	3A	4B	6A
LO7 – legacy of NINES on Shetland economy?	1A		3A		6A
LO8 – legacy of NINES on carbon footprint?			3B		6A

3. List of Contributors

NINES Team Member	Affiliation
Colin Mathieson	Scottish&Southern Electricity Networks
Stevie Adams	Scottish&Southern Electricity Networks
Fraser MacIntyre	Scottish&Southern Electricity Networks
John Stapleton	Scottish&Southern Electricity Networks
Karen Halley	Scottish&Southern Electricity Networks
Nathan Coote	Scottish&Southern Electricity Networks
Casey Bauchope	Scottish&Southern Electricity Networks
Laura Kane	Smarter Grid Solutions
Robert MacDonald	Smarter Grid Solutions
Fulin Fan	University of Strathclyde (EEE)
George Bell	University of Strathclyde (EEE)
Han Xu	University of Strathclyde (EEE)
Ivana Kockar	University of Strathclyde (EEE)
Mohamed Edrah	University of Strathclyde (EEE)
Olimpo Anaya-Lara	University of Strathclyde (EEE)
Andrew Cowie	University of Strathclyde (ESRU)
Joe Clarke	University of Strathclyde (ESRU)
Kati Svehla	University of Strathclyde (ESRU)
Raheal McGhee	University of Strathclyde (ESRU)
Grant Allan	University of Strathclyde (FAI)

4. Glossary

(D)DSM	(Domestic) Demand-Side Management (a method of controlling the average load on a network by managing the amount of energy stored and released)	GIS	Geographic Information System (see https://www.gislounge.com/what-is-gis/)
Airwave	Operator of a secure radio communications network throughout UK	Glen Dimplex	A manufacturer of electric heating products and domestic appliances, headquartered in Ireland
ANM	Active Network Management system (an SGS product)	HHA	Hjaltland Housing Association (a provider of rented accommodation in Shetland)
ACG	ANM Controlled Generation (non-firm distributed generators under flexible contracts)	Home Hub	The wireless transceiver (a Glen Dimplex product) which communicates with the storage heaters and hot water cylinders within a building
BESS	Battery Energy Storage System	LIC	Local Interface Controller
Carbon Footprint	A method to measure the total amount of greenhouse gases produced directly and indirectly to support human activities, usually expressed in equivalent tons of carbon dioxide (CO2)	LPS	Lerwick Power Station (the base generator on Shetland)
DER	Daily Energy Requirement (an estimate of energy required for next day)	NAS	Sodium Sulphur battery technology
DNO	Distribution Network Operator	NINES	Northern Isles New Energy Solutions
DOPF	Dynamic Optimal Power Flow (a computer modelling package for electrical power networks)	PI	OSIsoft software product used to provide data archival, retrieval and display functions for operators and engineers. SSEN has an instance of PI for their entire network in Scotland, known as PI Power Systems North. A new, dedicated instance of PI, known as PI Shetland, has been installed to support the NINES project.
EEE	Electronic & Electrical Engineering (a department of Strathclyde University)	Quantum	A range of electric heating products from Glen Dimplex
EM	Element Manager (an Airwave product)	SGS	Smarter Grid Solutions (software and systems supplier, headquartered in Glasgow)
ESRU	Energy Systems Research Unit (a division of the Engineering faculty of Strathclyde University)	SSEN	Scottish & Southern Energy Networks
FAI	Fraser of Allander Institute (the Economics department of Strathclyde University)	SVT	Sullom Voe Terminal (a gas-turbine generator, contracted to SSE to provide energy as required by the Shetland network)
Fuel Poverty	Currently households are considered by the UK Government to be in 'fuel poverty' if they would have to spend more than 10% of their household income on fuel to keep their home in a 'satisfactory' condition (SPICE, 2016)	UoS	University of Strathclyde, Glasgow



Scottish & Southern
Electricity Networks



0345 300 2315



www.ssen.co.uk/innovation

